



---

# ANGULAR POSITION

---

Sponsored by 



SENIOR DESIGN 1

GROUP 14

SPRING 2018

4/23/2018

AMBER HALEY – ELECTRICAL ENGINEERING

JENNA SOTO – ELECTRICAL ENGINEERING

BENJAMIN WILLIAMSON – COMPUTER & ELECTRICAL ENGINEERING

# Table of Contents

<b>1.0 Executive Summary</b>	<b>1</b>
<b>2.0 Project Background</b>	<b>1</b>
<b>2.1 Motivation</b>	<b>2</b>
<b>2.2 Objectives</b>	<b>2</b>
<b>2.3 Requirements Specifications</b>	<b>2</b>
<b>3.0 Research</b>	<b>2</b>
<b>3.1 Existing Similar Projects and Products</b>	<b>3</b>
3.1.1 Safety Monitoring Device and System	3
3.1.2 BreathaLock	3
<b>3.2 Sensor Options</b>	<b>3</b>
3.2.1 Encoder	4
3.2.1.1 Measurement Type	4
3.2.1.2 Styles	4
3.2.1.3 Technologies	4
3.2.1.4 Mounting Types	5
3.2.1.5 Turn Types	6
3.2.1.6 Additional Information	6
3.2.2 Linear Variable Differential Transformer	6
3.2.3 Programmable Angle Sensor IC	7
3.2.3 Contactless Sensor	7
3.2.4 Sensor Conclusion	7
<b>3.3 Wireless technology</b>	<b>8</b>
3.3.1 Wireless Options	10
3.3.2 Z-Wave Specifications	12
3.3.3 Wireless Diagram	14
<b>3.4 PLC Characteristics</b>	<b>15</b>
3.4.1 CPU	15
3.4.2 Power Supply	15
3.4.3 I/O Modules	16
3.4.3.1 Sinking and Sourcing	16
3.4.3.2 Types	16
3.4.4 PLC Types	17
3.4.4.1 Fixed PLC	17
3.4.4.2 Modular PLC	17
3.4.5 PLC Sizes	18
3.4.6 PLC Manufacturers	18
3.4.7 PLC Conclusion	18
<b>3.5 Battery types</b>	<b>19</b>
3.5.1 NiMH/ NiCd	19
3.5.2 Lead Acid	20
3.5.3 Li-Ion/ Polymer	21
3.5.4 Alkaline	22
3.5.5 Battery Conclusion	23
3.5.6 Environmental Safety	25
<b>3.6 Battery Management System</b>	<b>26</b>
<b>3.7 Voltage Regulator</b>	<b>26</b>

<b>3.8 Microcontroller</b>	<b>26</b>
3.8.1 MSP430G2	27
3.8.2 Arduino Mega	27
3.8.3 Arduino Uno	27
3.8.4 Raspberry Pi	28
3.8.5 Peripherals	28
<b>3.9 IDE Comparison</b>	<b>28</b>
3.9.1 CodeBlocks	28
3.9.2 Eclipse	29
3.9.3 Qt Creator IDE	29
<b>3.10 Programming Language Comparison</b>	<b>29</b>
3.10.1 Java	30
3.10.2 C/ C++	30
3.10.3 Python	30
<b>3.11 Zero Button</b>	<b>30</b>
<b>3.12 Robust Design</b>	<b>30</b>
3.12.1 Waterproof Enclosure	31
3.12.2 Dehumidifier	33
3.12.2.1 Silica Packets	33
3.12.2.2 Filters	34
<b>3.13 PCB Design</b>	<b>34</b>
3.13.1 Programs	34
3.13.2 Board Manufacturers	35
<b>4.0 Related Standards</b>	<b>35</b>
<b>5.0 Project Hardware and Software Design Details</b>	<b>35</b>
<b>5.1 Concepts A and B Presented to [REDACTED]</b>	<b>36</b>
5.1.1 General Concept A	36
5.1.2 General Concept B	38
5.1.3 Concept Chosen Conclusion	40
<b>5.2 Component Selection</b>	<b>41</b>
5.2.1 Battery	41
5.2.2 Voltage Regulator	43
5.2.3 Balance Charger	44
5.2.4 Battery Monitor	45
5.2.5 Encoder	45
5.2.6 Encoder Coupling	46
5.2.7 Microcontroller	46
5.2.8 Z-Wave Module	47
5.2.9 Push Button	48
5.2.10 PLC	48
5.2.11 Weatherproof Enclosure	49
5.2.12 Silica Packets	49
5.2.13 Humidity Indicator	50
<b>5.3 Printed Circuit Board (PCB)</b>	<b>51</b>
5.3.1 PCB Specifications	51
5.3.2 Soldering Components	51
5.3.2.1 Soldering Paste	51
5.3.2.2 Soldering Wire	51
<b>5.4 Software Development Process</b>	<b>52</b>

<b>6.0 Project Prototype Construction and Coding</b>	<b>53</b>
<b>6.1 Hardware Fabrication</b>	<b>53</b>
6.1.1 Hardware Block Diagram	54
6.1.2 Hardware Integrated Circuit Designs	54
6.1.3 Hardware Assembly Drawings	55
6.1.4 On-Board Housing Assembly Details	63
6.1.5 Way-Side Housing Assembly	64
<b>6.2 Software Fabrication</b>	<b>67</b>
6.2.1 On-Board Housing Assembly	67
6.2.2 Way-Side Housing Assembly	67
<b>6.3 Coding</b>	<b>68</b>
6.3.1 Microcontroller Coding	68
6.3.2 PLC Coding	69
6.3.3 PCB Coding	70
<b>6.4 Prototype Maintenance</b>	<b>70</b>
<b>7.0 Realistic Design Constraints</b>	<b>70</b>
<b>7.1 Time and Economic Constraints</b>	<b>71</b>
<b>7.2 Manufacturability and Sustainability Constraints</b>	<b>71</b>
7.2.1 Durability and Expected lifetime	71
7.2.1.1 Durability	72
7.2.2 Portability	72
7.2.2.1 Light Weight/ Relatively Small	72
<b>7.3 Health, Safety, and Environmental Constraints</b>	<b>73</b>
7.3.1 Hazardous Analysis	73
7.3.1.1 Likelihood	73
7.3.1.2 Fault Tree Analysis	75
7.3.1.3 FMEA's	76
7.3.1.4 Fail Safe	77
7.3.2 Environmental Constraints	79
7.3.2.1 Temperature	79
7.3.2.2 Wind	79
7.3.2.3 Light/ Dark	80
<b>7.4 Ethical, Social, and Political</b>	<b>80</b>
<b>7.5 Constraints</b>	<b>80</b>
7.5.1 Accurately Transmit and Receive data	83
7.5.2 Reliably Transmit and Receive Data	83
7.5.3 Angular Position Accuracy	84
7.5.4 In Range Display	84
7.5.5 Out of Range Display	84
7.5.6 Battery Level Display	84
7.5.7 Signal Received Display	85
7.5.8 Stop Request Display	85
7.5.9 Angular Position Display	85
7.5.10 Standard Voltage for Battery	85
7.5.11 Commercial Off the Shelf Parts	85
7.5.12 Supported for PLC I/O	86
7.5.13 Potential Use in Dynamic Situations/ Environments	86
7.5.14 Vibration Tolerant	86
<b>8.0 Project Assembly</b>	<b>86</b>

<b>9.0 Project Prototype Testing</b>	<b>87</b>
<b>9.1 Microcontroller Testing</b>	<b>88</b>
<b>9.2 Encoder Testing</b>	<b>88</b>
<b>9.3 Test Environment</b>	<b>88</b>
<b>9.4 Transmitter Test Procedures</b>	<b>88</b>
<b>9.5 Wireless Communication</b>	<b>88</b>
<b>9.6 PLC Test Procedures</b>	<b>89</b>
<b>10.0 Administrative Content</b>	<b>89</b>
<b>10.1 Project Milestone</b>	<b>89</b>
<b>10.2 Budget and Finance</b>	<b>94</b>
<b>10.3 Team Organization</b>	<b>94</b>
<b>10.4 House of Quality</b>	<b>95</b>
<b>Appendices</b>	<b>96</b>
<b>Appendix A – Copy Right Permission</b>	<b>96</b>
A.1 Powerwerx	96
A.2 Battery – MaxAmps	96
A.3 Raspberry Pi	97
A.4 Angle Position Sensor IC	97
A.5 Information Reference - Spend Edge	98
A.6 Encoder	98
A.7 Encoder Coupling	99
A.8 Z-Wave.Me RaZberry Z-Wave plus GPIO card	99
A.9 16 mm illuminated push button – blue momentary	100
A.10 Dry & Dry silica packets and humidity indicator cards	100
A.11 12x10x5 Inch Weatherproof Windowed NEMA Enclosure	100
<b>Appendix B Data Sheets</b>	<b>101</b>
B.1 Encoder	101
B.2 Raspberry Pi 2Model B	107
B.3 Micro USB Power Supply	108
B.4 Z Wave Me RaZberry	109
B.5 Powerwerx Watt Meter	109
B.6 Battery Charger – SKYRC iMAX B6AC V2	110
<hr/>	<b>110</b>
B.7 Voltage Regulator – DROK LM2596	111
B.8 Circuit Breaker (fuse) – Digiten Auto Standard Blade Type ATV Fuse	111
B.9 Weatherproof Enclosure – L-Com Weatherproof Windowed Enclosure	112
B.10 Silica Packets – Dry & Dry 5-gram Silica Packets	115
<b>Appendix C Bibliography</b>	<b>115</b>

## Table of Figures

<i>Figure 1: Wi-Fi range comparison</i>	<i>11</i>
<i>Figure 2: Representation of Z-Wave mesh network</i>	<i>14</i>

Figure 3: Concept A Block Diagram	37
Figure 4: Concept B Block Diagram	39
Figure 5: MaxAmps 11.1V Battery (permission)	42
Figure 6: DROK LM2596 Voltage Regulator (pending approval)	43
Figure 7: iMAX B6AC v2 balance charger (pending approval)	44
Figure 8: Powerwerx Watt Meter	45
Figure 9: US Digital Miniature Absolute Magnetic Shaft Encoder	45
Figure 10: Encoder Company Flexible Coupling	46
Figure 11: Raspberry Pi 2 Model B	47
Figure 12: RaZberry Z-Wave Plus GPIO Card	47
Figure 13: Illuminated Pushbutton	48
Figure 14: Weatherproof Windowed NEMA Enclosure	49
Figure 15: 30 pack of 5-gram Silica Gel Packets	50
Figure 16: Dry & Dry Humidity Indicator card	50
Figure 17: Software Block Diagram	52
Figure 18: Software Development Planning	53
Figure 19: System Block Diagram	54
Figure 20: Integrated Circuit Design	55
Figure 21: Encoder Assembly Drawing	56
Figure 22: On-Board Control Box Assembly Drawing	57
Figure 23: Track Side Box Assembly Drawing	58
Figure 24: Power Box Assembly Drawing	59
Figure 25: Way Side Control Panel Assembly Drawing	60
Figure 26: Way Side Control Panel Detail "A" Assembly Drawing	61
Figure 27: Way Side Console Assembly Drawing	62
Figure 28: Way Side Control Panel Detail "B" Assembly Drawing	63
Figure 29: On-Board Schematic	64
Figure 30: Track Side Box Schematic	65
Figure 31: Way Side I/O Schematic	66
Figure 32: PLC Power Supply Schematic	67
Figure 33: Fault Tree Analysis of Problems	75
Figure 34: Failure Modes and Effects Analysis (FMEA)	76
Figure 35: On-board failsafe code flow diagram	77
Figure 36: PLC Fail Safe Tree	78
Figure 37: In Range and Out of Range Angles	84
Figure 38: Microsoft Project Schedule pg. 1	90
Figure 39: Microsoft Project Schedule pg. 2	91
Figure 40: Microsoft Project Schedule pg. 3	92
Figure 41: Microsoft Project Schedule pg. 4	93

## Table of Tables

Table 1: Test frame and conditions to determine link quality	13
Table 2: Nickel Cadmium Battery Advantages and Disadvantages	20
Table 3: Nickel Cadmium Battery Advantages and Disadvantages	20
Table 4: Lead Acid battery advantages and disadvantages	21
Table 5: Lithium Ion Battery Advantages and Disadvantages	22
Table 6: Lithium Polymer Battery Advantages and Disadvantages	22
Table 7: Nominal Voltage Cell Comparison.	23
Table 8: Life Span Cell Comparison	24
Table 9: Charge Time Cell Comparison	24
Table 10: Other Characteristics of Each Battery	25
Table 11: LiPo Battery Specification from Supplier	42
Table 12: Voltage Regulator Specification from Supplier	43

Table 13: Battery Charger Specification from Supplier	44
Table 14: Software Update Chart	53
Table 15: Output Truth Table for way-side receiver	65
Table 16: PLC Truth Table	69
Table 17: Maintenance Routine	70
Table 18: Likelihood Table for mitigation	74
Table 19: Truth table for algorithm comparison output	78
Table 20: Requirements / Specifications Fulfillment Table for On-Board	81
Table 21: Requirements / Specifications Fulfillment Table for Way Side	82
Table 22: Test frame and conditions to determine link quality	83
Table 23: Battery monitor value reference table	85
Table 24: The cost of the parts needed	94
Table 25: House of Quality	95

## Table of Acronyms

AES	Advanced Encryption Standard
AP Project	Angular Position Project
CB	Circuit Breaker
CDT	C Development tools
DLL	Data Link Layer
EEPROM	Electrically Erasable Programmable Read-Only Memory
FER	Frame Error Rate
FMEA	Failure Mode and Effects Analysis
FSO	Free-Space Optical Communication
FTA	Fault Tree Analysis
GPIO	General Purpose Input / Output
IEEE	Institute of Electrical and Electronics Engineers
I/O	Input / Output
IP	International Protection Marking
ISM	Industrial, Scientific, and Medical
ITU RR	International Telecommunication Union Radio Regulations
ITU-T	International Telecommunication Union - Telecommunications
ICD	Integrated Circuit Design
IDE	Integrated development environment
JDT	Java Development Tools
LCD	Liquid Crystal Display
LLC	Logical Link Control
LVDT	Linear Variable Differential Transformer
MAC	Medium Access Control
MCU	Microcontroller Unit
NEMA	National Electrical Manufacturers Association
NFC	Near-Field Communication
OSI	Open Systems Interconnection
PCB	Printed Circuit Board
PDT	PHP Development Tools
PIN	Personal Identification Number
PLC	Programmable Logic Controller

PHY	Physical Layer
QR	Quick Response
RAM	Random-Access Memory
ROM	Read-Only Memory
RF	Radio Frequency
RSR	Stop Request
S2	Security 2 Protocol
SAR	Segmentation and Reassembly
SDP	Software Design Plan
STD	Standard
TB	Terminal Block
WORA	Write once run anywhere
WPA2	Wi-Fi Protected Access II
MOSFET	Metal-Oxide-Semiconductor Field-Effect-Transistor
BJT	Bipolar Junction Transistor



## 1.0 Executive Summary

The Angular Position Project (AP Project) is a University of Central Florida senior design project being sponsored by [REDACTED]. The project is to capture angular position and use that information for future analysis. The Angular Position Project (AP Project) uses an on-board encoder attached to the shaft of the test object to read the test object's linear angular position. Once the angular position is obtained, the encoder feeds that information to an on-board microcontroller for processing. The microcontroller will take in the analog data, run it through its algorithms to decide if the test object is operating in an "in range" mode or "out of range mode". Then the microcontroller gives the data to an on-board transmitter. The transceiver packages the data then sends it wirelessly to a wayside transceiver. From the transceiver, the data is sent directly to the way-side PLC.

In addition to the wireless signal, the PLC will have three other inputs. The stuck button will simulate if the test object is in a fixed position or stuck position. The polling button will simulate movement of the test object as if it was progressing around a [REDACTED] track. The [REDACTED] key button will simulate some [REDACTED] personnel physically inserting a key into a turn lock to reset the [REDACTED] stop request error. As each piece of data enters the PLC, the PLC program will decide if a wireless signal was received, if the test object is in or out of range, is stuck or not stuck and if a [REDACTED] stop request should be issued. Once the PLC makes the decision, it will illuminate the appropriate light. There will be a light for signal received, in range, out of range, stuck, not stuck and [REDACTED] stop request. Each polling point will reset the data in the PLC and therefore reset all the lights except for the [REDACTED] stop request. The only way to reset the [REDACTED] stop request light is if the abnormality has been fixed and the [REDACTED] key button has been pressed; then the [REDACTED] stop request light will reset. The on-board components are powered by a rechargeable battery. The battery sends the power through a voltage monitor then to a voltage regulator to step down the power for component protection. The power through a battery monitor, which will monitor the battery level at all times. The battery tester sends the power to the on-board microcontroller. The microcontroller then provides the power to the encoder and the transceiver. The way-side microcontroller will be powered from a power supply that is plugged directly into the wall. The PLC will be powered directly from the wall. The input stuck button, the input polling button and the input [REDACTED] key button will be powered by a power supply. All output lights will be powered directly from the PLC output module.

## 2.0 Project Background

The next sections will introduce the angular position system by giving an overview of the motivation behind the project, objectives, and the requirement specifications. This will cover the background behind the project and what needs to be accomplished. It will go into a more technical description moving forward.

## **2.1 Motivation**

The angular position concept came about when wanting to get a [REDACTED] sponsored project for senior design. After further considering this concept, its reach can be introduced to much more diverse systems, from construction equipment to even airplane instruments. This will be an accurate and reliable system that will help other engineers, contractors, or manufactures. Adding a better way to measure angular position is a compelling way to help with expanding on how far mechanical systems can go.

## **2.2 Objectives**

Transmission of angular position in all appropriate conditions. This includes indoor, outdoor, rain, temperature, day, night, etc. The goal is to produce a functioning prototype that proves the technology is not only possible, but that it can also meet the requirements specified. The desired result would be that the developed concept is capable of being incorporated into a [REDACTED] control system.

## **2.3 Requirements Specifications**

The initial requirements of the sponsored project will be to: accurately transmit and receive data, reliably transmit and receive data, be supported for PLC I/O, standardized not customized, light weight, potential use in dynamic situations/environments, vibration tolerant, fail safe, relatively small, water resistant, and function in Florida weather ([REDACTED] operational conditions) such as sunshine, water resistant, heat, fog, windy, light, dark, etc.

## **3.0 Research**

In creating a project, researching the different components and other similar projects will help in choosing which components to use. Researching about the other similar projects that use components that we could use in our project will give the understanding of the different options that can be considered for this system. For each component it is good to know how much power consumption each will take. Using the data sheets for the components will help also understand how to help supply the voltage needed for all the components that will be used in this project. For this project, the research was done for the following components and topics: a sensor for angular position, wireless technology, microcontroller, waterproof casing, battery types, PLC's, voltage regulator, and battery monitors. Each component and topic will be extensively researched until a decision is made on what component to use that would be the best option for this project. The decision will be based on examining the parameters of the components abilities and dimensions.

## **3.1 Existing Similar Projects and Products**

Through the developmental stage of the angular position accuracy, it was apparent that this project was unique. With this being said the components that are used for this project are not much different from previous projects. In researching the past projects, the primary aspect was use of wireless communication and angle sensors that would provide an accurate angle within +/- 1%.

### **3.1.1 Safety Monitoring Device and System**

The Safety Monitoring Device and System project focused on creating and developing a device for monitoring safety. They incorporated a network that would link together each device that will provide the status of each device in the building that will relay a signal back on if a fire or explosion has happened. The system detects by using sensors and then will send the signals of each device to a centralized computer that will keep the logs of any triggers that happen from fire explosions. This is kind of relevant to this project in a couple of ways. One way is that we will also send back a signal from our encoder that would have to be interpreted to tell if the test object is in range or out of range.

For the Safety Monitoring Device and System project they chose their data base structure to group all data into a text file. Each text file will split up into emergency and system logs. The text file storage as they said was not very secure since the files can be edited by anyone with access. This gave us the idea to keep a log system like this but instead of using a computer we decided to use the microcontrollers memory.

### **3.1.2 BreathaLock**

BreathaLock is a device that is to take in place of a key fob that would start the car to prevent drunk driving. The driver will take out the BreathaLock that will do a biometric fingerprint to make sure that it is the driver for the car. If the driver is sober it will unlock the vehicle remotely. If the user did not pass, then the BreathaLock will deny the driver. This helped us with installing a key switch needed to the PLC [REDACTED] when checking the system. If the angle is out of range and stays out of range, stuck, or no signal, which will illuminate a light until fixed. Then a key switch is needed making sure the person officially came out and check on the system.

## **3.2 Sensor Options**

There are several different types of sensors on the market that can read angular position. In our brainstorming sessions, we came up with several different ideas that could potentially work for this design project. One idea was to shoot a beam from a sensor at a mirror and when the beam reflects back, measure the angular position. The problem with this idea was that moisture on the sensor or the mirror

would cause false information. From these brainstorming sessions, we were able to produce several different sensors that would read angular position.

## **3.2.1 Encoder**

An encoder is a special sensor that captures position information, and sometimes speed as well as direction, then relays the data to other devices. When deciding what encoder to choose, there are several different areas to look at. There are so many different types of encoders on the market, we were only able to scratch the surface of the encoder world, therefore we are only listing the encoder types we researched for this design project.

### **3.2.1.1 Measurement Type**

An encoder reads position. There are two different position types that lead to two different types of encoders. A linear encoder, as the name suggests, reads linear position. This type of encoder is used to determine position in a straight line and are normally used in application for things like a coordinate measuring machine. The other type of position is angular position. As an object turns in a circular motion, a rotary encoder reads the angle of the rotation. Rotary encoders are widely used in industry to track the position of a motor shaft.

### **3.2.1.2 Styles**

There are two major styles of encoders that treat position differently. An incremental encoder provides position relative to a “home” position. This detection of position is usually done with a pulse output. A single wave output will give indication of movement only meaning, it will signify when the shaft moved and how much it moved but not in which direction it moved. A two-channel quadrature output, meaning A+, A-, B+, B- will give how much the shaft moved and in which direction. The two channels are 90 degrees out of phase from each other and by taking the difference between the 4 outputted square waves, an angle of rotation can be obtained. This means that incremental encoders only deal with digital data. A drawback of incremental encoders is loss of position with loss of power. This is an issue if a power outage occurs, the encoder must be referenced back to the home position to reinitialize the counter. The other major style of encoder is an absolute encoder. The absolute encoder does not lose the position when a power outage occurs therefore the position is available immediately when the power returns to the encoder. The absolute encoder also assigns unique identifiers to each position, so it does not need to reference a “home” position to maintain position accuracy. Absolute encoders, unlike incremental encoders, come in both digital and analog versions.

### **3.2.1.3 Technologies**

Encoders have several types of technologies available on the market. The two most dominate are the optical encoder and the magnetic encoder. The optical

encoder uses a glass or plastic disk with transparent or opaque sections. A light source shines through the disk and the photo detector reads the pattern projected through. Optical encoders have microprocessors built in to decipher the patterns being projected which equates to a position. For example, an optical incremental encoder, utilizes a disk which contains equally spaced sections to determine movement whereas an optical absolute encoder utilizes a disk which contains concentric circle patterns and a masking disk. A light is passed through the mask then through the disk. The photo detector picks up the unique light pattern which produces a distinct output for each position. Optical encoders have the highest resolution, meaning they are the most accurate, on the market.

The magnetic encoder has a series of magnetic poles inside the encoder. There are at least 2 poles, sometimes more. The position of the poles is read by a magnetic sensor. The pole positions are sent to a built-in microcontroller to decipher the pole position information. The microcontroller then produces an angular position much the same way an optical encoder does. Magnetic encoders are more rugged than optical encoders as they are manufactured for dirty, industrial environments.

There is a new addition to the encoder market called a capacitive encoder. They offer comparable resolution to an optical encoder but are built to withstand rugged environments like a magnetic encoder. Since they are a relatively new introduction to the market, there are only a handful of vendors offering this encoder. Due to their limited availability, not further research was done on this encoder.

### **3.2.1.4 Mounting Types**

How the encoder mounts to the shaft of a motor or test object can vary so there are various mounting types to consider. The first type is a hub shaft encoder which fits the shaft of the motor inside the encoder bore. This means that the shaft length of the motor must be exact, within millimeters, for the encoder to function properly. This type of encoder is usually designed to fit certain types of motors so that the shaft length will match up correctly with the specified encoder. Then there is the thru-bore encoder. This encoder is circular in shape with a hollow hole in the middle just like a doughnut. The shaft of the motor or test object goes through the center hole. This allows for unlimited size in the shaft length. The center hole, also known as the bore hole, is usually lined with some type of rubber to prevent the encoder from moving rotationally on the shaft or linearly along the shaft. Next there is the regular shaft encoder which has a circular solid shaft that protrudes from the encoder. This shaft is to be inserted into a bore that accepts that shaft size. Therefore, instead of the motor or test object inserting a shaft inside the encoder like the previous two mounting types, this encoder inserts its shaft into the motor or test object. The last type is a flange shaft encoder which is the same as the regular shaft encoder with one slight difference. The encoder shaft is not completely round, it has a portion that is squared, creating a flange. The flange is to be inserted into a bore that accepts flange style shafts. This allows for proper lining up of the encoder to the motor or test object so if you were to use an

incremental encoder, the “home” position would be easier to locate because of the flange.

### **3.2.1.5 Turn Types**

There are additional layers of information that can be tracked by some encoders such as the number of turns or revolutions an encoder makes. In certain applications, the number of times an encoder turns are important therefore such applications would use a multiturn encoder. This encoder counts the number of turns as well as its position and its direction. Some even track speed, depending on the need for such information. If the number or revolutions are not important to the application, they offer single turn encoders which does not track revolutions only position and direction.

### **3.2.1.6 Additional Information**

While researching encoders, there were a few additional points that were noticed along the way. There is a line driver encoder which provides error-free output pulses in electrically noisy environments or over long transmission lines. These types of encoders are used for cable lengths for up to 1,000 feet. A line driver is a sourcing output, sinking and sourcing is discussed under the PLC research, therefore it would need a sinking input to function properly. Another topic that was noticed while researching encoders is that one of the most prevalent kinds of outputs for incremental encoders is an open collector output. The open collector has a sinking output and would need a sourcing input to function. An open collector utilizes pull up resistors to pull in the signal to supply the voltage. In the same research on an open collector, we came across a push-pull output which is a combination of a line driver and an open collector. This design also utilizes pull up resistors. In the off state it will supply a path to ground and in the on state it will supply voltage.

## **3.2.2 Linear Variable Differential Transformer**

Another type of sensor we discussed was a linear variable differential transformer. This device measures linear displacement. The basic idea is there is a core inside of a hollow shaft. The hollow shaft is wrapped with wire, just like a transformer, on the north and south poles of the shaft to give the displacement. A third coil is wrapped over the middle part of the shaft, where the core sits inside, and a power source is fed through this third coil. The magnetic flux produced by the middle coil is coupled to the two pole coils inducing voltage in each coil. The core is attached to the object that is being measured and as the object moves, the core slides freely inside the hollow shaft between the two coiled poles. The displacement from the middle, which is the core’s “home” position, will determine the location of the object. There are great benefits in using LVDTs for displacement measurement because the LVDT is highly robust. There is no physical contact across the sensing element, so the element has no wear and tear. The device relies on magnetic flux, so it has infinite resolution. The slightest movement in the core will

result in a measurable displacement, so the only limit on the resolution is the data acquisition system interpreting the displacement. It should be noted that most LVDTs require an AC power source, though there are some on the market that do offer a DC power source option.

### **3.2.3 Programmable Angle Sensor IC**

This programmable angle sensor is a pinned component that uses the hall effect for angular position. This chip was an ideal part at first because it is a contactless sensor which would make being mobile a lot easier. These chips are used in industrial, automotive, and consumer markets. Some applications for this chip sensor is steering wheel angle, torque and rotational speed. The contactless angle sensor goes from 0 to 360. The designed is to use a magnet to a diameter of 15mm and a thickness of 4mm to be rotated.

It is a non-volatile memory (EEPROM) with a single or dual die option that can support up to about 100 read/write cycles. This chip has 5 pins for VCC, VOUT, and the rest are NC which is connected to ground. The input voltage need for this chip is between 4.5V and 5.5V and a current draw of 12 mA to 15mA which would great with the low current draw to make portable. After researching, our sponsor did now want anything that had to be custom, so this idea had become scraped.

### **3.2.3 Contactless Sensor**

The final sensor that was researched was a non-contact sensor. This sensor operates using the hall effect technology with generating a magnetic field by magnets. This sensor is a linear sensor. Some good advantages for this sensor is that it is non-contact so less wear and tear on the component, a full 360-degree rotation with a high tolerance for misalignment. Another advantage is that it only pulls 8mA which is one of the lowest out of all the sensors previously discussed. Usual applications for this sensor are for lifts, steering, and outboard trim sensing. One disadvantage for this sensor was the air gap. The air gap is the gap between the sensor and the magnet. The air gaps on most of the sensors similar to this was at most was 44mm which we need more room for more rotation on our test object.

### **3.2.4 Sensor Conclusion**

The LVDT was a viable choice until we were unable to find any DC options with a low power requirement. The lowest power option was a 12VDC which was too much power to be considered for this design. The programmable angle sensor IC was not considered because it did not meet the sponsor requirement of being a commercial off the shelf part. It was a chip that would have to be attached to something, not an actual component. The contactless sensor was another possible choice for the design project and was included in concept B (see section 5.1.2 for concept details) to be presented to our sponsor. The other feasible idea

was an encoder to read the angular position. This was included in concept A (see section 5.1.1 for concept details) to be presented to our sponsor.

There are many different types of encoders on the market. There were several features that we were looking at to decide which encoder to choose. The encoder would be on exposed to the outside elements, so moisture and dirt would be a major concern. Optical encoders would not be the best choice because they are very sensitive to moisture and dirt, so we chose a magnetic encoder which is more rugged. The tradeoff is that a magnetic encoder cannot achieve the resolution or accuracy of an optical encoder, but for our application, the magnetic encoder will exceed the requirements set forth by the sponsor. The encoder needs to retain information if there is a power outage otherwise it could send incorrect data leading to a safety issue. This means the encoder must be an absolute which assigns a specific identity to each angle so if the encoder loses power, the angle will not reset back to zero like an incremental encoder would.

There are several mounting types to choose from. Since the shaft length of the test object is not known, we wanted to use a design that could easily be adapted to any shaft length. This ruled out the hub shaft encoders. We didn't want to limit the shaft to a flange style, so we ruled out the flange encoders. That left the hollow shaft and the regular shaft encoders to pick from. Either one would work for the design, so we looked at other factors to help make that choice. We wanted a small foot print, so the encoder needed to be light weight and relatively small in construction. Both hollow shaft and regular shaft encoders could meet that requirement. Ultimately, we did not know what size shaft could be used on a future design that would be able to meet the weight requirements for a swinging component so without knowing what diameter of shaft could be incorporated, we chose the regular shaft encoder to give more flexibility to the design.

### **3.3 Wireless technology**

Wireless communication was chosen as the preferred method of data communication for this project. The transmission of data can be generalized into two high-level categories which are wireless and wired communication. Wireless communication is the process of sending data between two or more points without the use of an electrical conductor. Wired communication is a data communication method that takes information directly from the source and transmits as a set of high and low voltage, or amperage, values through conductive material to the host device.

The advantages and disadvantages of wired and wireless were used in the decision process of choosing wireless over wired for our project. The advantages of wireless communication are the number of devices that can easily be connected in a network, maneuverability of wireless devices indoors, and the large available bandwidth for communication over the network. One advantage of wired communication is that it's a robust form of data communication since it's normally sent through conductive material surrounded by a thick layer of insulating material



to help mitigate harmful electromagnetic waves. Another advantage to wired is the wide availability of different methods of wiring and standards that define how much data it can send and how the data is sent. The disadvantages of wireless communication are interference of signals using the same bandwidth to send data, operating range of higher frequencies, and the absorption of electromagnetic waves that travel through conductive materials. Wired disadvantages are clutter of wire, inability to move wired devices due to limited wire length, and if parallel communication is used with transmitting data through a wire the data has a high likelihood of colliding causing data loss.

Wireless communication was overall preferred because it suited the needs of maneuverability of the project and it came with other advantages over wired communication. There were two possible wireless communication methods that were considered for use in the project. The two methods, or modes, were radio/microwave electromagnetic wave transmission and free-space optical communication. Free-space optical communication, or FSO, uses propagating light to transmit data from point to point in free space (air, outer space, vacuum, etc.) and is normally used in situations that physical connections are impractical. The radio wave mode of wireless communication uses the radio and microwave bandwidths on the electromagnetic spectrum to transmit data wirelessly from one device to another. Radio waves are able to do this by modulating the properties (amplitude, frequency, phase, pulse width, etc.) of the electromagnetic waves to represent the data being sent.

The advantages and disadvantages of both modes were then weighed the same way wireless and wired communications were to decide which one our project would need. One advantage of FSO is license-free long-range operation which meant that acquiring a license to use a bandwidth would not be necessary. Other advantages are high bit rates and low bit error rates meaning reliability and accuracy in the sent data. The last notable advantage of FSO is the immunity to electromagnetic interference because the data is sent as propagated light which is not affected by electromagnetic waves. A disadvantage to this mode of wireless communication is that it is highly affected by any change in atmospheric condition (rain, fog, smog, snow, wind, etc.). This disadvantage alone is the only one that truly matters for our project because the environment that Florida has will cause transmission issues for free-space optical communication.

The radio waves mode has multiple advantages including ease of application, satisfies communication range requirement for the project, and multiple frequencies to choose from to send data through. The ease of application comes from wireless radio communication being well established in most forms of wireless communication. These applications encompass long range satellite communication, which uses bandwidths in the microwave electromagnetic spectrum, to short range device to device communication such as Bluetooth. The next advantage of radio communication having a sufficient range for the project refers to having bandwidths that can transmit data to a distance of at least 50

meters away. The last advantage of multiple frequencies to choose from refers to the operating frequencies of 3 kHz to 300 GHz, but this brings in the first disadvantage of this system. Even with the large range of frequencies, only a limited set can be chosen because of regulations set by the National Telecommunications and Information Administration, which is run by the US Department of Commerce. The frequencies that can be chosen freely for the project are set by the Radio Regulations of the International Telecommunication Union, or ITU RR, and these frequencies are in what is known as the ISM bands. Another disadvantage is high propagation loss after a set distance, but the distance is different for each bandwidth that can be used. The last applicable disadvantage to the project for radio waves is interference of other devices that use the same bandwidth. Overall, the better choice between the two different wireless communication modes for our project was using the radio mode.

Additional pertinent information on this mode comes from the ISM bands. The ISM (Industrial, Scientific, and Medical) bands are, as stated previously, set by the ITU RR for the purposes other than telecommunications. A majority of the frequency bandwidth allocations are for telecommunications, radio station broadcasting, or television broadcasting. The purpose of the ISM bands is to allow researchers, enthusiasts, and students to use them to implement different applications to these frequencies. The ISM bands also provide options of different wireless radio communication to use which are Bluetooth, Wi-Fi, Z-Wave, and NFC (Near-Field Communication). These will be compared to determine which of these is best suited for the project.

### **3.3.1 Wireless Options**

There were five different options that were researched of the radio mode of wireless communication that the angular position project could use. These five were NFC (near-field communication), Bluetooth, Wi-Fi, Zigbee, and Z-Wave. Beginning with NFC as a method of communicating data it was immediately considered as non-viable option because it didn't meet the range requirement due to its communication range being at most 20 cm. The next option considered was Bluetooth which provided a further operating range compared to NFC. NFC was at most 20 cm, where Bluetooth could be anywhere from 50 meters to 100 meters depending on if it is low energy or not. There were two issues with using Bluetooth: The standard they were designed from is no longer maintained and lack of proper signal security. The standard not being maintained means that if there are issues that pertain how the signal is packaged and sent, it is on the programmer to customize the networking code to properly send the signal. This conflicts with a parameter set by our sponsor of not having "customized" devices for their portion of the project and having to modify a standard fall under this set parameter. The disadvantage of the lack of security was a major issue as well because the data that is procured by the project is going to be treated as sensitive information that only designated users can access. Bluetooth devices that are in discoverable mode to pair with other devices share the device name, device class, list of

services, and technical information. For the purpose of this project, the stated shared information to any device using Bluetooth is sensitive info in relation to our project. The sensitive information carried by the project, and the security of that information, was reason enough to not consider Bluetooth as an option.

The next option that was considered was Wi-Fi. Wi-Fi is wireless local area networking working with devices based on the IEEE 802.11 standard. IEEE stands for the institute of electrical and electronics engineers and the institute created standard 802.11 as a set of specifications for the MAC and PHY layers for implementing wireless local area networks. This standard specifies how devices built using it accesses the 900 MHz, 2.4 GHz, 3.6 GHz, 5 GHz, and 60 GHz frequency bands to communicate data. The approximate range of each frequency respectfully are greater than 100 meters, 70 meters, 50 meters, 35 meters, and 3.3 meters. Figure 1 shows a comparison of the ranges of the 900 MHz, 2.4 GHz, and 5 GHz frequencies that Wi-Fi uses. The power consumption of each frequency increases respectfully as well from 900 MHz, being the lowest power method, to 60 GHz, being the highest power consuming. The next aspect of Wi-Fi that was considered was the security of the network which the standard has a subsection 802.11i that defines a protocol called Wi-Fi Protected Access II, WPA2. WPA2 is a robust security network with two interlaced protocols: The four-way handshake and the group key handshake. This protocol provides a robust security network for Wi-Fi networks that require this to connect to a desired network. Taking all this in to account, the low-power long-range option of the 900 MHz frequency Wi-Fi device was desired for use in the project to send data. The down-side of this choice was limited availability of devices to use for the purpose of the project. Researching devices that use the 900 MHz ISM band provided two promising results: Zigbee and Z-Wave.

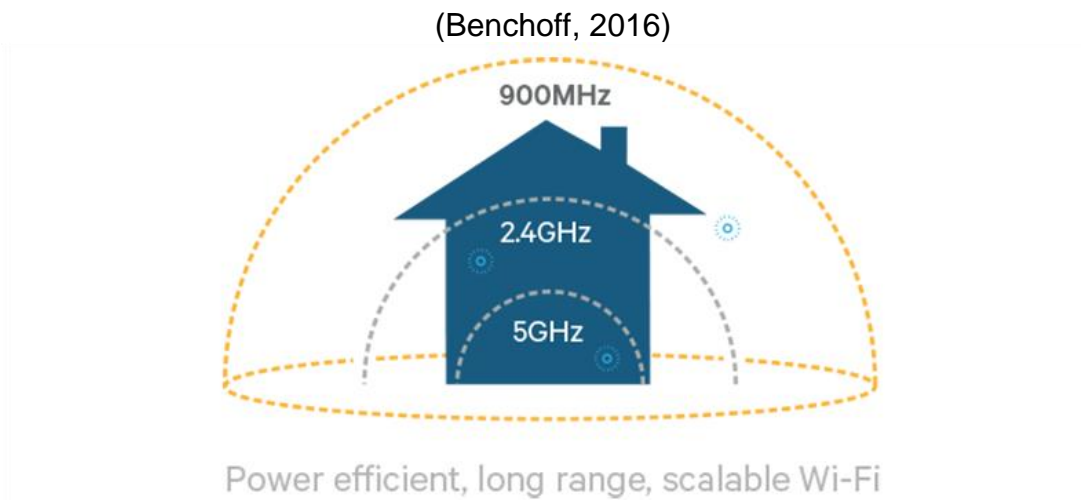

**Figure 1: Wi-Fi range comparison**

Zigbee and Z-Wave devices are similar to each other in a few ways with a couple of key differences that influenced the decision for one over the other. One major

comparison between the two is that neither need access to the internet to operate and send data between devices. This is a significant advantage over Wi-Fi devices because it isolates the Zigbee and Z-Wave devices from security breaches from other devices over the internet. Another comparison between the both of them is that they have the operating frequency of 900 MHz and are low-power which is a factor in why they were chosen in the first place. They are both also easily implemented into systems and networks and widely available for purchase and installation. The first key difference is that Zigbee devices have an approximate transmitting range of 10-20 meters, whereas Z-Wave devices have an approximate range of 60 meters indoor and 100 meters outdoor. The second difference is that they both use separate standards that specify how the different network layers work in their networks. Zigbee uses IEEE 802.15.4 which is similar to IEEE 802.11 in the sense that it only defines how devices specify their PHY and MAC layers in networking with each other. Z-Wave uses recommendation ITU-T G.9959 which not only specifies how devices access the PHY and MAC layers, but also the SAR and LLC layers. In conclusion, a Z-Wave device was chosen as the preferred method to wirelessly communicate data for our transmission of angular position project.

### **3.3.2 Z-Wave Specifications**

After the decision to use the Z-Wave wireless communication protocol was made, research on how it specifies what the network layers should do before sending data and how it encrypts the data was needing procurement. The previously stated ITU-T G.9959 recommendation was found to be the document describing how Z-Wave determines how the PHY, MAC, SAR, and LLC layers should be specified. ITU-T is the International Telecommunications Unions telecommunications branch and the document title G.9959 refers to this document dealing with transmission systems and media, digital systems and networks with focus on access networks - in the premises of networks. The second important aspect that was researched was the how the security of the Z-Wave networks is established. The security of the network is determined by the Security 2, or S2, protocol specially designed for Z-Wave devices.

OSI model stands for Open Systems Interconnection model and it standardizes the communication of telecommunication or computing systems. The reason the OSI model exists is to serve the goal of interoperability of the growing diverse communication systems with standard protocols. The layers of the OSI model that the G.9959 recommendation specifies are the physical layer and data link layer. The PHY layer is the entirety of the physical layer, the MAC layer and LLC layer make up a majority of the data link layer, and the SAR layer is an optional layer that goes in between the MAC and LLC layers in the data link layer.

First is the PHY layer which is responsible for anything that has to do with assigning profiles to devices, whether or not to transmit or receive data, making sure there is no interference, and what bandwidth to use. This layer is directly above the transceiving medium which means it is as closely related to the hardware its using

to wirelessly communicate data. This layer is also responsible for determining link quality in a signal by sending test frames that ascertain specific conditions as shown in . The other important function of this layer is setting the transceiving bit rate, modulating the signal, and determining the minimum receiver sensitivity before stopping a signal.

(International Telecommunications Union , 2015)

Term	Definition	Conditions
Standard test frame	PHY frame used for testing sensitivity.	PHY frame with at least four bytes of random payload data.
Frame error rate (FER)	Average frame loss.	Average measured over standard test frames.
Receiver sensitivity	Threshold input signal power that yields a specific FER.	FER < 1% Power measured at antenna terminals. Interference not present.

**Table 1: Test frame and conditions to determine link quality**

The MAC, Medium Access Control, layer controls access to the network and the layer also confirms the transceiving of frames from one device to another. The specifics it handles is assigning a HomeID for the domain, a NodeID to each device in the domain, and to assure that frames are transmitted without error or collision. This layer assigns a 32-bit HomeID for the domain and subsequent 8-bit NodeIDs for all the devices in the domain. The size of the NodeIDs allow for the possibility of 256 devices to be connected in a domain, but because of reserved NodeID values the maximum number of devices that can be in a single domain is reduced to 232. The LLC, logical link control, layer is directly above the MAC layer and the final part of the data link layer. The LLC layer handles only one thing: encryption/decryption of MAC protocol data units which tell the MAC layer what tasks it needs to perform. The SAR, segmentation and reassembly, layer will not be utilized for the project because the size of data the transceivers will be working with are no more than a couple of bytes. The SAR layer deals with breaking up large amounts of data in to multiple segments when transmitting and then reassembling said data when it received. The ITU-T G.9959 recommendation has an Annex A that deals with how this recommendation applies specifically to Z-Wave devices. The Z-Wave PHY and MAC layers are still responsible for all of the same things that are specified by the general G.9959 documentation.

The recommendation G.9959 deals with how the data is sent through the different layers and if the devices can connect under certain conditions. The data link layer is where security encryption is applied but it does not specify what encryption method it uses. The Security 2, or S2, protocol was created by the Z-Wave Alliance through reverse engineering successful hack attempts to their previous Security 0 protocol. A key feature of this protocol is the pairing procedure requires a unique PIN or QR code for a device to connect to the network. The only way to obtain these PINs or QRs is by physically requesting one for the network. This means that for someone to intrude in on to this network they have to physically interact

with the domain device to access the network. The type of encryption the transmitted data has in open-air is an AES-128 encryption which stands for Advanced Encryption Standard with a key size of 128 bits. Even though AES-128 has the smallest key size of 128-bits, it is still practically impossible to decipher.

In summary, the Z-Wave specifications meets all the desired requirements by our transmission of angular position project. The approximate transmission range is 60 meters at minimum and 100 meters at maximum, it is low-power, available as off-the-shelf products, easily implementable, and secure.

### 3.3.3 Wireless Diagram

Figure 2 is a rough representation of how a Z-Wave mesh network looks on the level where you can only see the links and nodes of the network. Each of these nodes in the figure are assigned a different NodeID to differentiate themselves from each other. Since they are all interconnected, they are all part of the same unique domain defined by a HomeID which they all share. The two determining factors of how one node sends data from one of the other: number of hops to the destination node and latency between the nodes. The number of hops means how many nodes the data has to pass through before reaching its destination node. The latency between the nodes is the time it takes to send the data from node to node. Both of these factors are determined by how far away the source node is from the destination node. Normally, the algorithm that determines what path the data should take will take the path with the least latency. This algorithm is implemented on top of methods that help the data transmit with little to no errors, so the networking aspect it takes in to account on a high level is transporting the data from end to end as fast as possible.

(International Telecommunications Union , 2015)

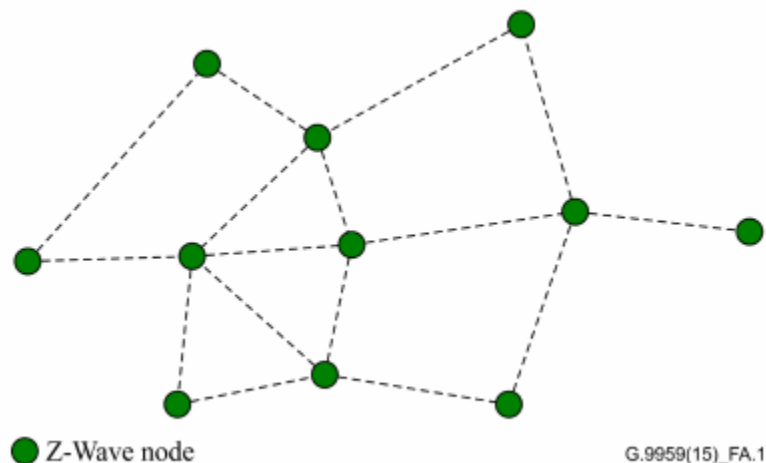

**Figure 2: Representation of Z-Wave mesh network**

## **3.4 PLC Characteristics**

A programmable logic controller is an industrial computer that has a robust construction and reliable controlling capabilities that make it a major asset in control industries. There are many different types, models and styles of PLCs. Even with such a diverse selection on the market, there are some similarities. Every PLC has a minimum of three modules; a CPU module, a power supply module and at least one I/O module.

### **3.4.1 CPU**

The CPU module is the brains of the entire system which consists of a central processor and its memory. The memory includes both ROM and RAM but are utilized a little differently in a PLC than in a personal computer. In a personal computer, ROM is used for storing data that does not get lost when the computer is turned off. This includes the operating system, drivers, programs and saved documents. RAM in a personal computer temporarily stores data that has not been saved to ROM such as a word document that you've started typing but have not saved it in your documents folder yet or when you add numbers on the calculator on the desktop. If you shut down your computer without saving the document, all your work will be lost. The calculator with the added numbers will not start up on your computer the next time you power it up. That is a generalized example of RAM and ROM work on a personal computer, but a PLC is different. In a PLC, ROM is also used for the operating system, drivers and application programs but does not store any user data such as documents. Any user data or external data is stored in RAM. This consists of user written programs and data being received from other inputs. In essence, the user does not have access to the ROM only the RAM. Just like the personal computer ROM, the PLC RAM is able to retain the information stored in it even when the power is turned off. This is called retentive memory. This means that when the PLC starts up again, the user programs loaded into the memory are still there. This alleviates the need for the PLC to be connected to a computer. Once the user program is downloaded into the PLC, no other interaction is needed unless the user wants to change the programming.

### **3.4.2 Power Supply**

The power supply module powers the CPU and the I/O modules. Many times, the power supply takes in AC power and converts it to DC power. Some power supply modules are manufactured to take in a DC power which allows for power flexibility depending on what is needed for your application. Some PLCs are able to use some of the power delivered from the power supply to drive a few sensors and/or actuators. That depends on the I/O cards, which will be discussed in the next section.

### **3.4.3 I/O Modules**

The input/output modules, I/O modules, of the PLC take in data from external sources and send out data to external sources. For example, in a personal computer, the user typing at the keyboard or using a mouse is the equivalent of a sensor sending pressure information to a PLC. The user is inputting the data into the PC whereas the pressure sensor is sending the data to the PLC. The input module takes in the data and uses the user-written program to decide what to do with that data. The PLC output module sends data to external sources to turn on or send a specific signal. For example, in a personal computer, when you press the play button on a YouTube video, the sound comes out of the speakers and the video plays on your computer screen. This is the same idea for the PLC. When the data is processed, the output module can light up a warning light or signal a motor to turn on or sound a buzzer, etc.

#### **3.4.3.1 Sinking and Sourcing**

How the inputs or outputs get their power depends on the I/O card. There are two types of power options, sinking or sourcing. Sinking is when the current comes from another source, known as the sourcing current, into the PLC, then the current sinks to ground. Sourcing is when the current comes from the PLC, which then becomes the sourcing current, to another device, such as a limit switch, to power the device. The device is then grounded on the other side. The most often used setup is for a sinking input card and a sourcing output card. This allows for the PLC to power other devices such as the warning light or the sound buzzer without the need to add an additional power source to the design.

#### **3.4.3.2 Types**

Aside from the power options, sinking and sourcing, there are various types of input and output cards that handle different types of data. The three most common are the analog I/O module, the digital I/O module, and the communications interface module. The analog input module reads real-time data in the form of voltage differences. This means the analog input is sending different voltage sizes to the PLC that represents a continuous data stream. The PLC takes those different voltages and converts them into a digital package, so in essence, the PLC changes the analog information into a digital form, so the processor can understand the data. This is called an analog-to-digital converter. The analog output module would be the same process, but in reverse, to send out analog information, which is actually just like a digital-to-analog converter. In the digital input module, the information coming into the PLC is already in digital form, meaning it is either on or off, so there is no conversion needed at this point. That is the same with the output, the PLC will send either on or off to the outputs. The communication interface module has one job and that is to send and receive information between the PLC CPU and the communication network. This allows for the CPU and other PLCs or computers in remote locations to talk to each other.



## **3.4.4 PLC Types**

As noted above, there are three modules every PLC has, a CPU, a power supply and at least one I/O module. That is where the similarities end. There are different types of PLCs and numerous manufacturers of PLC. There are two types of PLCs, fixed and modular, and a few assorted sizes to choose from.

### **3.4.4.1 Fixed PLC**

A fixed PLC, also referred to as an integrated or compact PLC, come as a packaged set. This means the manufacturer decides the CPU, the power supply and the I/O modules inside the PLC. All the components are wired together and contained inside a housing. This means that the user must choose from what the manufacturer provides and does not leave any room for flexibility. Some integrated PLCs can attach additional I/O's together, so it does leave some room for expansion. One plus is that they are out of the package complete and there is no assembly required.

### **3.4.4.2 Modular PLC**

A modular PLC is one that can be built using different modules. This increases the flexibility and the expansion ability of the PLC. The user has their choice of power supply module, CPU module, input module, output module and communications module. This allows the user to customize the PLC to their specific needs. With this type of customizability, there is some assembly required to link all the modules together. The modules are positioned inside a chassis which has slots and a back plane. Chassis come in different sizes, usually in 4, 8, 12 or 16 slots. The slots are where the different modules slide into and plug into the backplane in the back of the chassis. The backplane is how all the modules are able to communicate with each other. The backplane is also where the power supply provides power to all the other modules.

It should be noted that in industry the term “chassis” is often replaced with the term “rack”. People mistakenly think a chassis is a rack because the Merriam-Webster dictionary defines the noun rack as “a framework, stand, or grating on or in which articles are placed.” (Merriam-Webster, 2018) In those terms a chassis can be called a rack but that is an incorrect substitution when it comes to PLCs. When referring to a PLC, a rack is not a piece of hardware, it is actually referring to the input/output points. A rack, technically called a logical rack, “is an addressable unit consisting of 128 input points and 128 output points. A rack uses 8 words in the input image table file and 8 words in the output image file.” (Petruzella, 2005) When you talk about a logical rack, you are referring to 16 words of data not a physical piece of hardware. Considering the varying chassis sizes and different I/O module sizes, there can be more than one rack in a chassis and more than one chassis in a rack.

### **3.4.5 PLC Sizes**

PLC's come in three different sizes, small, medium and large. A small PLC is a compact and robust PLC that is usually mounted either on a unit or near the equipment being controlled. This PLC is not very complicated. It generally replaces hardwired components like counter, timers and relays. The most common reason you would replace these hardwired components with a PLC is because it is much easier to change the programming in a PLC than to change physical hardware. For example, if you wanted to change a timer to a different time interval, to accomplish that with physical hardware requires rewiring and possibly different components. With a PLC, it's as easy as changing the program inside. The small PLC does not allow for much expandability though. It is limited to one or two modules at most. The medium PLC is what most of the PLC industry uses. These PLC's are the ones that have several modules and are mounted on a backplane of the system. Each module added, increases the I/O points providing the potential for hundreds of points of information flowing to and from the PLC CPU. In addition to the I/O module, there is also the capacity to add in communications modules allowing the PLC to communicate with other remote devices. This type of PLC is very versatile and covers a wide range of applications. That is why it is the most popular choice for the controls industry. The last PLC size is the large PLC. These PLC's are extremely complex and have much higher specs than the medium PLC. The large PLC has more memory, more I/O points, more modules, more programming languages, etc. "Mostly, these PLCs are used in supervisory control and data acquisition (SCADA) systems, larger plants, distributed control systems, etc." (Agarwal)

### **3.4.6 PLC Manufacturers**

There are several manufacturers of PLCs and they span the entire globe. Wikipedia lists almost 50 different manufacturers, but some are more common in the United States where as others are more common in the other countries. A market report done in October of last year listed the top 5 PLC manufacturers as Siemens, Rockwell Automation, Mitsubishi Electric, Schneider Electric and Omron (Global Programmable Logic Controllers Category - Procurement Market Intelligence Report, 2017). Siemens is a German company that is the lead supplier in the PLC industry. Runner up is Rockwell Automation which is an American company who bought out Allen Bradley. The other manufacturers listed are based in Japan, France and Japan respectively. Each offer many types of PLCs to fit most applications.

### **3.4.7 PLC Conclusion**

The most common PLC used in the industry is a medium size PLC therefore, we felt a medium sized PLC was best suited for our application. Also, we liked the flexibility of a modular PLC so additional I/O modules or communication modules could be added if necessary, so we narrowed our search to a modular PLC. There are many different manufacturers of a medium sized modular PLC. We looked at

the top 5 PLC companies listed in our research section. We felt using an American based company would be best suited for our project for procurement of parts and the laws regulating the manufacturing of parts would be familiar to us, so we could better guarantee quality of parts. This led us to the only American option, Rockwell Automation (Allen Bradley) as our PLC manufacturer of choice. Rockwell offered many different types of CPU modules, power supply modules, I/O modules and communication modules.

### **3.5 Battery types**

For this on-board concept we will need a battery that will power the microcontroller and the encoder. First in consideration was to choose between a primary battery and a secondary battery. The primary batteries are a disposable battery because of their electrochemical reaction cannot be reversed, while a secondary battery is a rechargeable battery because the electrochemical reaction can be reversed. The second part in considering a battery is to make sure that it has a long-life span and last at least 24hrs before replacement or recharging. Other issues would be energy density, power density, safety, and cost.

Keeping in mind that encoder takes a voltage input of 4.5-5.5V with current draw of 0.016A with a max of 0.020A and the microcontroller taking a voltage input of 5V with a current draw of 1 amp determined on what size battery is needed. Nowadays there are many batteries to choose from, but the ones that were researched for this project are a Nickel-Metal Hydride (NiMH) battery, Nickel-Cadmium (NiCd) battery, Lead Acid battery, and a Lithium-ion (Li-ion) battery.

#### **3.5.1 NiMH/ NiCd**

First battery researched was a Nickel-Metal Hydride battery. The chemistry of this battery is a hybrid between a positive electrode with energy storage characteristics. These designs are generally made with a metallic case where the tops are electrically insulated from one another. NiMH are built with a low resistance which allows the battery to have high performance. Extreme temperatures, such as below zero degree Celsius, will reduce the capacity in the battery which results in voltage reduction. There is a lot of problems that can affect the cycle life of a nickel-metal hydride. Some affects are temperature, storage conditions, overcharging, and age. If all conditions can be controlled the average cycles of life obtained from this kind of battery is about one thousand cycles which hindered its success since it is lower than Nickel Cadmium. In Table 2, is the advantages and disadvantages of a nickel-metal hydride battery.

<b>Advantages</b>	Higher capacity than NiCd Environmental friendly Large temperature range Less affected to memory than NiCd Rejuvenated
<b>Disadvantages</b>	High discharge, lower service life Does not take overcharge well Heat produced when fast charging Efficiency average of about 65%

**Table 2: Nickel Cadmium Battery Advantages and Disadvantages**

Another nickel-based battery is a Nickel Cadmium battery founded by Waldemar Jungner in 1899. Nickel-Cadmium batteries have a characteristic of high cycle life, most rugged, reliability, and most forgiving battery. Some applications for a portable use of the sealed type is in consumer electronics, toys, power tools, and cameras. Portable sealed NiCd batteries require no maintenance and can be recharged up to about 2000 times. The NiCd batteries to need proper care to keep up the longevity. Since this battery has a memory effect which causes loss of capacitance if a full discharge cycle is not given. In Table 3, is the advantages and disadvantages of a nickel cadmium battery.

<b>Advantages</b>	Large cycle life Rugged Can be used with fast charging High load performance, forgiving Can be stored for a longer time Good performance in low temperatures Fairly priced Difference sizes available
<b>Disadvantages</b>	Lower energy Has memory effect The metal used is toxic High discharge rate Cells of 1.2V, lot of cells for high volts

**Table 3: Nickel Cadmium Battery Advantages and Disadvantages**

### 3.5.2 Lead Acid

Lead acid batteries were invented by a French physician, Gaston Plante in 1859, for the first rechargeable battery. The great advantage of a lead acid battery is that it is dependable and on a cost per weight, inexpensive. The structure of the battery is from a lead alloy because using a pure lead would not support itself and a lead alloy improves its strength. A lead acid battery is heavy and less durable compared

to a nickel or lithium base battery. If a full discharge is given to a lead acid battery takes away a small percentage of the capacity. These batteries have an average cycle of 200-300 cycles. They have such a small cycle life because of the corrosion that happens on the positive electrode.

For charging purposes, it is simple to charge a lead acid batter. If charging at a low voltage, it gives the battery a worse performance and buildup of sulfate on negative plate. If charging at a high voltage, the performance gets improved but will still have corrosion on the positive side of the plate. Fast charging a lead acid is not preferable because it will start to heat up the battery, which heating up acid will cause an explosion. To charge a lead acid battery takes about 14 to 16 hours.

There are a few different types of lead acid batteries. There is a sealed lead acid battery, a starter lead acid battery, and a deep-cycle lead acid battery. The sealed lead acid battery has fewer electrolytes. An advantage of this sealed battery is that it can produce water to prevent from drying out during the cycling. The battery is also designed to reduce the gas that the battery generates during charging. The starter battery is to help start an engine type with a high-power load that should only last a few seconds by producing high current. These starter batteries are known for their low resistance. The plates in a starter battery are much thinner than in a deep-cycle battery. For a deep-cycle battery, is mainly built for golf cart like systems. The deep-cycle battery has a large capacity and a large cycle life. This battery has an average of about 5 to 20 hours of discharge. In Table 4, is the advantages and disadvantages of a lead acid battery.

<b>Advantages</b>	Cheap Low self-discharge Can give off high currents Low and high temperature allowance
<b>Disadvantages</b>	Heavy Small life cycle Not environmental friendly Slow charging rate

**Table 4: Lead Acid battery advantages and disadvantages**

### 3.5.3 Li-Ion/ Polymer

Lithium batteries began with G.N. Lewis in 1912. Lithium is one of the lightest metals out there which has a large energy weight. The average cell voltage is of 3.6 volts. Li-ion batteries have a low maintenance characteristic. This battery has no memory, so will last longer in terms of time. The self-discharge is less than a nickel-based battery. One of the disadvantages of Li-ion batteries is it needs protection from abuse. Lithium batteries also tend to cost more compared to the other batteries out there. Some devices that use Li-ion are laptops, cell phones, and hybrid cars. Lithium ion batteries are unstable and can be dangerous. Let's

say if the barrier inside the battery is broken that separates the negative and positive rods, a chemical reaction will happen. In Table 5 is the advantages and disadvantages of a lithium ion battery.

<b>Advantages</b>	High capacities Long cycle life Low self-charging No memory effect
<b>Disadvantages</b>	Thermal runaway (fire) Not tolerant for high temperatures Aging is an issue

**Table 5: Lithium Ion Battery Advantages and Disadvantages**

Another type of lithium battery is a Lithium polymer. This differs from the other batteries because of the electrolytes that are used. Lithium polymer cells are flexible and uses between a dry solid, a liquid chemical compound, or a gel-like material electrolyte. Some great characteristics of a lithium polymer battery is that they are robust, and lightweight. They do have a down fault and that is that they do not have a long-life span as a lithium ion battery. In Table 6, is the advantages and disadvantages of a lithium polymer battery.

<b>Advantages</b>	Robust Flexible Low profile Low change of leakage of electrolytes
<b>Disadvantages</b>	Expensive Less power Smaller life-span

**Table 6: Lithium Polymer Battery Advantages and Disadvantages**

### 3.5.4 Alkaline

Alkaline batteries are a primary battery, which means it is not rechargeable, but it is worth consideration due to its population because it is readily available and commonly used in devices. These batteries have a long shelf life that can be up to 8 years. One problem with alkaline batteries is that they do not work well in devices that have high draining such as digital cameras. In other words, they do not have an optimal requirement when it comes to having to power something that will require a lot of amperage. The voltage will drop significantly than NiCd or NiMH.

Another problem with alkaline batteries is that they have a high leakage. There leakage is higher than any other battery. If the battery is not constantly charged on a trickle-charger or an alternator, the battery will die in a short amount of time. Since this is a non-rechargeable battery it will have to be disposed of which is hard

to reuse and recycle this battery compared to the others. Even though they do not get reused it is still a better environment friendly over nickel-cadmium.

### 3.5.5 Battery Conclusion

There is a lot to consider when choosing the right battery for this project. In comparing all the batteries that was researched, the tables below are a summary of the cell battery comparisons for lead acid nickel-metal hydrate, nickel cadmium, lithium polymer, and lithium ion. These are the characteristics that was researched to choose the right battery for the system.

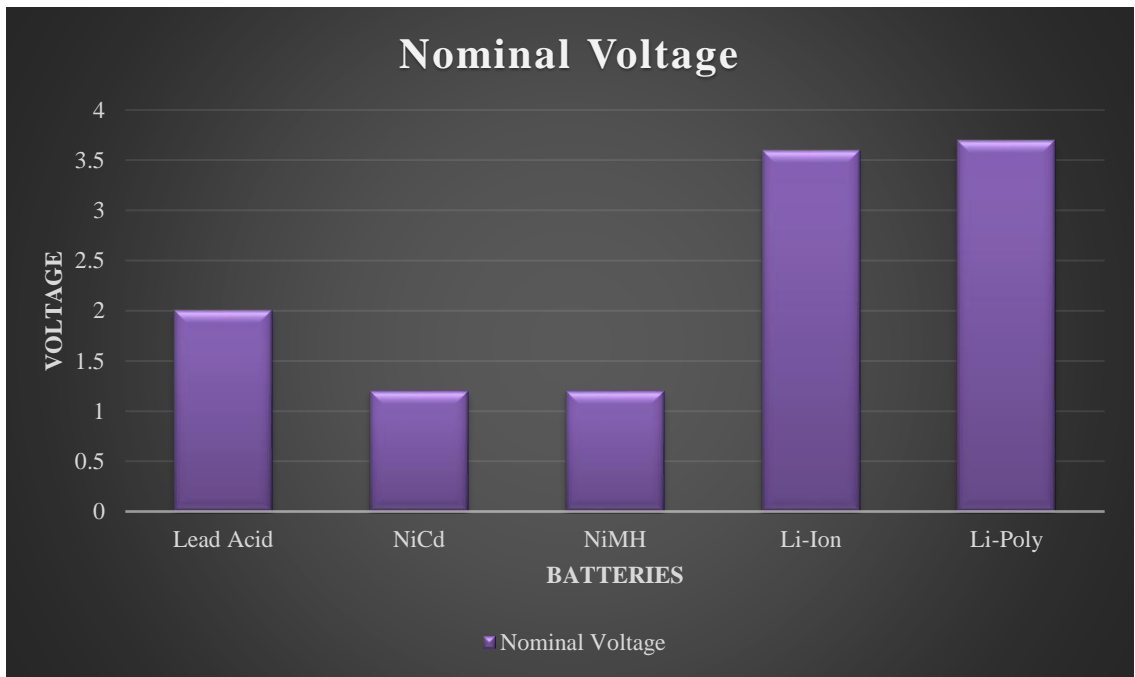

**Table 7: Nominal Voltage Cell Comparison.**

In Table 7, shows nominal voltage of each battery. Lithium polymer has a high nominal voltage for the cell that is 3.7V. While another lithium-based battery sitting at 3.6V. While the nickel-based batteries have the lowest nominal values for their cells. With the lithium polymer having the highest cell voltage means that can use less cells to achieve the voltage needed and less weight.

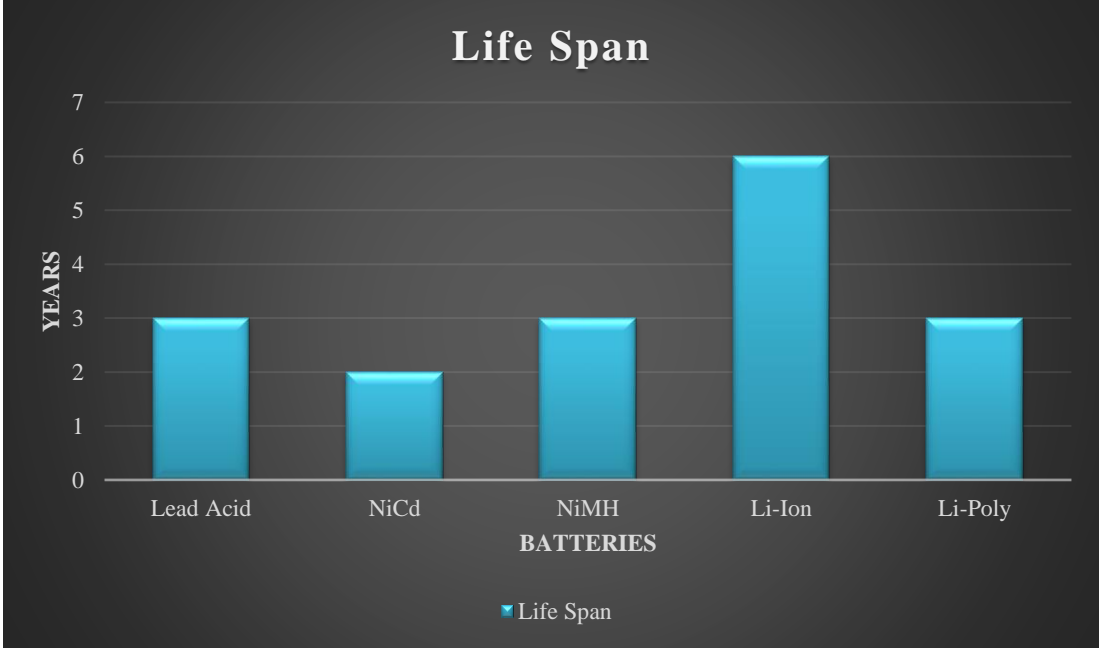

**Table 8: Life Span Cell Comparison**

Looking at Table 8 you can see that the life span for lithium ion cell batteries are the better choice as far as lasting a longer life span. The lithium ion cells have a life span of 6 years. Lithium polymer, nickel metal hydrate and the lead acid cells are the same when it comes to their life spans of about 3 years before needing to be changed out for newer ones. In last is the nickel cadmium battery sitting about 2 years before needing to replace the battery.

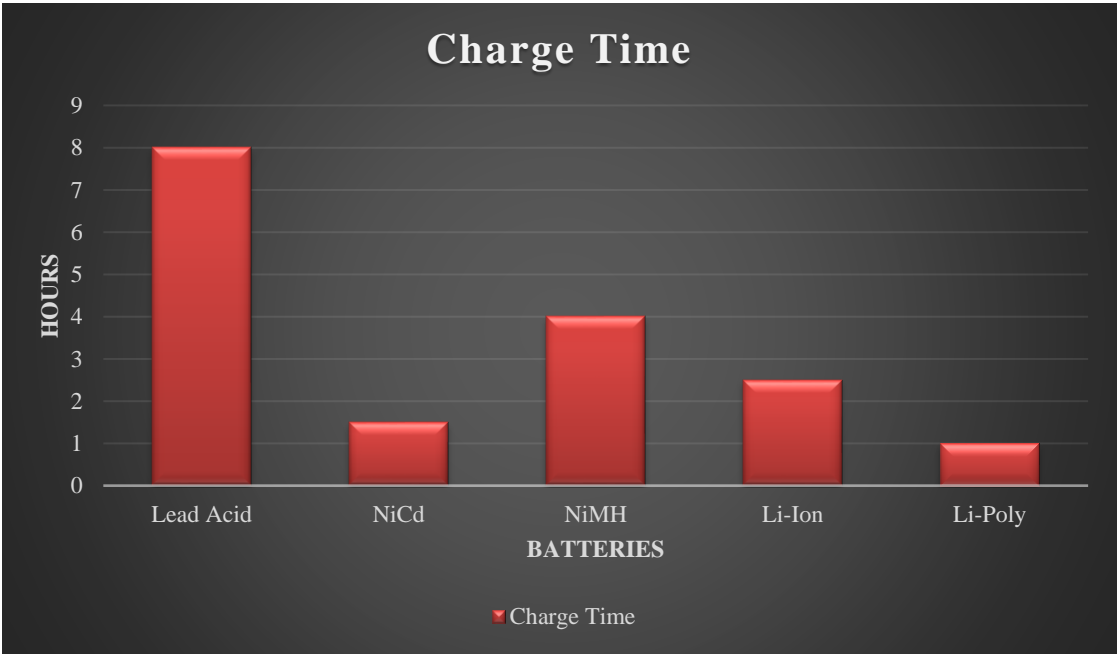

**Table 9: Charge Time Cell Comparison**



In Table 9 is the comparison of the batteries for their charge time. Lead acid batteries sitting at the top with an average of 8 hours for the cells to re-charge, which for our project would be unrealistic if we need it to be operational within a short time period. Lithium polymer is the fastest charging battery which will help with turn around when needing to charge the battery. Other comparisons that were made are in Table 10, with the list of the characteristics and the batteries.

	Lead Acid	NiCd	NiMH	Li-Ion	Li-Poly
Nominal Voltage	2V	1.2V	1.2V	3.6V	3.7V
Energy Density (Wh/kg)	40	45	90	160	130-200
Life(Years)	3	2	3	6	3
Charge Time (hrs)	8	1.5	4	2.5	1
Self-Discharge Rate (%/mo)	2-5%	10%	30-50%	2-8%	2-8%
Average Capacities (mAh)	4000-7000	600	2000	2000-6000	6000-12000
Average Cycle life	500-800	800-1500	500-1000	400-1200	>1000

**Table 10: Other Characteristics of Each Battery**

We concluded to use a lithium polymer battery. The lithium polymer was chosen because for the requirements that [REDACTED] wants, its characteristics best fit for what we are looking for in this project. It is a little costlier but more robust and a smaller design package that is needed. It also has a fast charging time and 3-year life span is more than what the sponsor is looking for with a cycle life greater than 1000.

### **3.5.6 Environmental Safety**

Lithium polymer batteries are environmental friendly but should be fully discharged before being disposed. If the temperature exceeds 140 degrees Fahrenheit gases are released off the lithium batteries. The most common gas is carbon dioxide, CO<sub>2</sub>, while other gases are vaporized electrolyte of propylene and ethylene. In

case of a fire of a lithium polymer battery using a foam extinguisher or even soda (sodium carbonate) will put out the fire.

## **3.6 Battery Management System**

The lithium cells chemistry has a possibility of a fire if the charging of the battery is not done correctly. To make sure that the battery is charged properly the charger settings have to be for a lithium battery and that both the voltage and current are correct on the charger before plugging in. Using a balance charger is an easier way to charge the battery because you can set all your parameters on the screen and then just plug in with a JST-XH connector. For example, if you have a lithium polymer battery that has a capacity of 4000mAh with a 5C rating, it would need to be charged at 20 amps.

## **3.7 Voltage Regulator**

We decided to use a voltage regulator to maintain a constant 5V that is needed for the microcontroller for a safety precaution, so it does not overheat with the unnecessary voltage. A voltage regulator gives an output of a fixed voltage that remains constant regardless of what input is being supplied. There are two different kinds of voltage regulators: linear and switching regulators.

The linear regulator has either a bipolar junction transistor, BJT, or a metal-oxide-semiconductor field-effect transistor, MOSFET, device controlled by a gain differential amp. What this does is it compares what the output voltage is with a reference voltage and then makes adjustments to the pass to the BJT or MOSTFET to keep the constant voltage that is wanted. Some advantages of a linear voltage regulator are the low ripple voltage, fast response time, and a low electromagnetic interference. A disadvantage is that it is not very efficient and needs large space.

For a switching regulator it converts a direct current input to a switched voltage that is applied to a power BJT or MOSTFET switch. This switch has a feedback to the circuit that helps control the power switch on and off times so that in the end, the voltage will remain the same regardless of what the input voltage will be. Advantages of a switching regulator is that they are efficiency, capable of higher power. The disadvantages are that it does have a higher ripple effect, electromagnetic emissions are very noisy, and also very expensive.

## **3.8 Microcontroller**

The overall project design constraints set by the sponsor requires the use of a microcontroller instead of a designed PCB. The use of the microcontroller will be to take in data from the encoder, zero or initialize the data, determine if the data is in range or out of range, and send it to the PLC in an efficient way. The method the microcontroller will use send the information is by using the previously chosen Z-Wave wireless communication. There will be one microcontroller communicating

to a second microcontroller wirelessly to send the data to the PLC. The microcontrollers will need to be of the same make and model for parallelization purposes to make the communication and interoperability between the two efficient. The microcontrollers being considered are the MSP430G2, Arduino Uno, Arduino Mega, and Raspberry Pi. Another part of the design that is taken into consideration when deciding on the microcontroller to use is the peripherals that are to be attached to send the data.

### **3.8.1 MSP430G2**

The Texas Instruments MSP430G2 series microcontroller is the simplest one on the list of considered microcontrollers. The simplicity of its design and any design using it is an advantage because it keeps power usage low, programs small in memory size, and has small dimensions to easily fit into smaller overall designs. The disadvantages are that the programs loaded to it cannot be too complex because of the limited flash memory and RAM and it does not have any available modules that are capable of using the Z-Wave method of wireless communication. Overall, the MSP430G2 did not meet the requirements of the project despite the familiarity of the device.

### **3.8.2 Arduino Mega**

The next possible microcontroller that could be used by the project is an Arduino Mega 2560. The Mega is a relatively large microcontroller that has 54 digital input/output pins and 16 analog inputs totaling 70 input pins. The advantage to this is that if the microprocessor on the controller can handle that many inputs it can handle the processing required to wirelessly transmit data. Another advantage, due to the size of the board, is that there's plenty of storage in the flash memory and RAM to implement the code that will be necessary to achieve the results needed by the microcontroller. The disadvantages of the Mega are that there will be multiple unused pins that are openings that could accumulate moisture, the power use of the Mega will be high relative to the other devices being considered, and the footprint of the device is much larger than the others being considered. In conclusion, the Arduino Mega can meet the requirements needed by the project but it will consume too much power to be considered as viable.

### **3.8.3 Arduino Uno**

The Arduino Uno is a smaller version of the aforementioned Arduino Mega 2560. Instead of 70 total input pins, there are instead 20 input pins on the Uno. The Uno having less input pins means there will be less unused pins to accumulate humidity and moisture from the air. Since the Uno is smaller than the Mega, it requires less power to operate which gives the Uno an advantage over the Mega. The downsides to the Uno is even though it has less pins that will be unused, the possibility of moisture accumulation still exists inside of the pinholes on the board. The advantages of the Uno come from it being a compact version of the Arduino

Mega. In summary, it's better than the MSP430G2 and Mega but it still has a disadvantage that could cause premature failure in the device.

### **3.8.4 Raspberry Pi**

The final microcontroller that was compared to decide which one to use for the project was the Raspberry Pi 2 Model B. This microcontroller was chosen for comparison because it is Arduino's strongest competitor in being a project microcontroller for hobbyists. Unlike Arduino boards, the pins on the Raspberry Pi 2 are all male instead of female. This provides an advantage to moisture accumulation because not only does it allow one to see if there is water building up on the pins, but it allows the pins to dry off on their own if sufficient airflow is provided. Another advantage to male pins is that they are easily covered with female pin protectors that can be added and removed as needed. The disadvantage of the Raspberry Pi 2 is that because of all of the different applications it can be used for it requires more power than the Arduino Uno to operate. The Raspberry Pi 2 Model B is the microcontroller that meets the most requirements provided by the project compared to the others listed above.

### **3.8.5 Peripherals**

The peripherals that come with the microcontroller or can be attached must be able to wirelessly communicate data using the Z-Wave specification stated previously. This requirement for a peripheral is what will decide what microcontroller to use for the project. After research, the only peripheral that was found was a Z-Wave module that can attach to and operate only with the Raspberry Pi boards.

## **3.9 IDE Comparison**

An IDE, Integrated development environment, is essential to how a programming language gets developed in to useable software. An IDE should be chosen before choosing a specific language to code in because some IDE's do not support all programming languages, or certain languages perform better in one IDE but not another. The IDE's being compared for use in the project are CodeBlocks, Eclipse, and Qt Creator IDE. The advantages and disadvantages of each will be considered in the following sections to determine which one will be chosen for use in the project.

### **3.9.1 CodeBlocks**

CodeBlocks was chosen as a possible IDE due to a majority of UCF faculty use it to teach programming and it also comes pre-installed on most of the computers on UCF campus. This immediate familiarity of the IDE provides the advantage of knowledge of how to use it and what it is capable of doing. Another set of advantages are that CodeBlocks is open-source, free, and cross-platform compatible which means using it can cut down on the cost of software needing to be bought for the project. The last advantage is because it is an open-source

program which means plugins can be installed for CodeBlocks to support other programming languages. This leads in to the disadvantage that without the plugins the IDE primarily deals with C++. Another disadvantage to using CodeBlocks is the non-interoperability of the software between the IDE and the microcontroller.

### **3.9.2 Eclipse**

The next IDE is called Eclipse and it is widely used as a Java IDE and is primarily used for developing Java applications. The other languages it can develop in are C, C++, C#, JavaScript, Perl, PHP, Python, and Ruby which are all well-known languages. Development environments that Eclipse comes with are JDT (Java Development Tools) for Java and Scala, CDT (C Development tools) for C/C++, and PDT (PHP Development tools) for PHP. The biggest advantage to Eclipse as an IDE is the ability to use most of the known high-level languages to code the software. Eclipse also has the advantage of being interoperable on multiple platforms including rich client platforms, server platforms, web tools platforms, and modeling platforms. A disadvantage of Eclipse is that it needs plugins to be able to support programming languages outside of Java and C. A slight disadvantage is that the latest version is a year old compared to CodeBlocks' latest version which is only four months old.

### **3.9.3 Qt Creator IDE**

The Qt Creator IDE was found through referencing the IDEs compatible with Raspberry Pi software development. Qt is a cross-platform IDE that primarily uses C++, JavaScript, and QML to program software. Qt includes a visual debugger, syntax highlighting, and auto completion and all of these are advantages to using this IDE over the other two being considered. Qt Creator also includes a project manager that can use a variety of project formats. This allows the programmer to separate functions of the project and integrate them later after their proved to work individually. Qt also released its newest stable released version in March 2018, so this is the most up-to-date IDE being considered. The disadvantage to Qt is that the only available languages to code in are C++, JavaScript, and QML. In conclusion after researching and comparing the three IDEs, the one being used for the project is the Qt Creator IDE.

## **3.10 Programming Language Comparison**

One thing that needs to be considered is the programming language that will be used to program the microcontroller. The usefulness of programming the microcontroller comes from being able to modify the incoming and outgoing data. The reason why the modification of data would happen is to make the PLC more efficient in determining the outputs of certain data ranges. The languages that will be considered based on knowledgeability are C/C++, python, and java. These languages were compared to determine the advantages and disadvantages of each. The following sections are the different languages that were compared to decide which one will be used for this project.

### **3.10.1 Java**

Java is a concurrent, class-based, and object-oriented programming language. The IDEs that use java as a main programming language tend to be too large to load on to the Raspberry Pi boards. The boards do have pre-loaded libraries or the ability to download the libraries in case that the board does not have them. The usefulness of using Java as a programming language for the project is that it is a WORA, Write once run anywhere, language. This means that as long as the code that is developed works on the platform that the Raspberry Pi boards provide, then the code can be ported over to a different platform. The downside of the language the size of the IDEs and libraries to make sure that it can be ported from system to system. Another advantage to Java is that it is a common programming language, so the available reference code packages are immeasurable.

### **3.10.2 C/ C++**

C/C++ are the most established programming languages used in modern day software building. C is a general-purpose programming language and C++ is its object-oriented counterpart. C/C++ doesn't come built-in for use on the Raspberry Pi boards but can easily be implemented by using the light-weight, in terms of memory size, Qt Creator IDE. These languages are preferred for use due to familiarity and the expansive set of function libraries to use for coding.

### **3.10.3 Python**

Python is an interpreted high-level programming language that is used mainly for general purpose programming. Python is also the standard programming language loaded to Raspberry Pi boards. The language was designed to emphasize code readability and have an extensive standard library. Python was designed with simplicity in mind and the only disadvantage to using this language is unfamiliarity with structure. Overall, python will be used to program the Raspberry Pi boards specified functions for the project.

## **3.11 Zero Button**

A zeroing button was desired for our project as per sponsor recommendation. The button will provide the microcontroller the means to know when the encoder and test object are in their initial position. The button will feed a high value to an input pin on the microcontroller which will then initialize the data being fed to the microcontroller. A simple push-button switch was chosen for the project to meet the requirements specified by the sponsor.

## **3.12 Robust Design**

The need for robust design for our project is due to the certain weather conditions that our project will experience. The weather conditions that the projects design needs to mitigate are rain, humidity, and temperatures that can reach 100 degrees

Fahrenheit. Other weather conditions such as lightning, high wind gusts, and low temperatures are non-factors in the design of the project and should not be considered when creating mitigating factors for the robust design. Rain will be mitigated by finding an enclosure for the project that has a NEMA rating that meets requirements. The next factor is humidity and that will be handled by either silica packets that absorb moisture. Another method that will be considered for dealing with humidity and temperature inside of the enclosure is to determine if a particular enclosure with vents, that will have filters that absorb humidity and block dirt and dust, will meet the requirements of robustness of the project. The other consideration of temperature to the robustness of the project was to choose components that have a relatively high tolerance to temperature compared to Florida temperatures. Research in weatherproof enclosures and dehumidification processes was done in that respective order.

### **3.12.1 Waterproof Enclosure**

The process for finding a weatherproof enclosure started off by knowing what NEMA enclosure type and IP rating we would need for the project. NEMA, National Electrical Manufacturers Association, defines the standards used in North America for different grades of enclosures used in industrial applications. Any NEMA enclosure type protects against personal access to hazardous parts. Along with the protection from hazardous parts, each NEMA enclosure type is a different designated environmental condition. These conditions range from, but are not limited to, general-purpose, drip-tight, weather-resistant, watertight, dust-tight, and submersible. Out of these conditions the two that were the most suitable to the project was weather-resistant or watertight. The respective types for these are type 3 and type 4 NEMA enclosure types. Type 3 NEMA enclosures are weather-resistant that also protect against falling dirt and windblown dust. Type 3 also protects against rain, sleet, and snow and undamaged by ice formation. Type 4 means the enclosure is watertight and it has a sub-type of 4X which adds corrosion resistance to the enclosure. NEMA Type 4 was determined the rating that would be necessary for the enclosure for the project's different components that need protection.

The other type of rating to consider is the IP Code, or International Protection Marking, which classifies and rates the degree of protection provided against intrusion, dust, accidental contact, and water by mechanical casings and electrical enclosures. The reasons why the IP code of the casing was taken in to account when choosing a specific weatherproof enclosure is because it is a standard used on the international level and it provides additional information as to what the enclosure protects against. The standard that is used is the IEC, International Electrotechnical Commission, standard 60529 which makes manufacturers using it provide detailed information about the ratings, protections, and testing procedures used to determine what the enclosure protects against.

The IP Code has a two-digit rating and the first digit determines the solid particle protection of the enclosure and the second digit determines the liquid protection of

the enclosure. The first digit of the IP Code rating goes from 0 to 6, but 5 and 6 are the only ratings that protect against dust entering the enclosure. First digit rating level 5 is considered to be dust protected which means that the enclosure will let in a level of dust that won't interfere with the operation of the equipment on the inside, but for the project this is a little less than satisfactory. The rating level 6 is considered to be dust tight based off of 8 hours of test time with air flow, so an IP code rating of at least IP 6x is what would be attained for the project.

The second digit of the IP Code ranges of 0 to 9K. Rating 0 means there is no protection against liquid introduction in the enclosure and 9K is protection against powerful high temperature jets. Ratings 7 and 8 are for immersion which are unnecessary for the project, since the project will not be immersed in water for any of the testing procedures. Rating level 1 is protection against dripping water, 2 is protection from dripping water when the enclosure is tilted 15 degrees in four different directions, 3 is protection for spraying water, 4 is protection from splashing water, 5 is protection from water jets, and 6 is protection from powerful water jets. The ratings 1, 2, and 3 do not meet the requirements given to use for the project, so the ratings considered were 4, 5, and 6. IP Code 64 barely meets the minimum requirements for the project because even though it is dust tight, it only protects against splashing water which was only tested for 10 minutes based on the standard the IP Code uses. IP Code 65 meets the recommendations because it is dust tight and protects against water jets and tested for a long enough duration to simulate heavy rain for 15 minutes. Even though IP Code 65 meets the needs for the project, what was decided is to get equipment that exceeds what was required for the project to insure robustness of our design. IP Code 66 is the rating that was decided to be necessary for the project based on using a necessarily excessive robust weatherproof enclosure.

The next step in procuring the necessary weatherproof enclosure is to decide between three types of weatherproof enclosures. The three types of enclosures are completely enclosed, vented, or windowed. These three provide the capability of having outlets on the inside of the enclosures in the case that power is provided to the enclosure. Due to the decision to provide power to our components using a battery the outlets in the enclosure would be redundant and unnecessary. A completely enclosed weatherproof enclosure provides the full protections that come from the NEMA rating and IP Code that were chosen to meet the needs of the project. The downside of a completely enclosed one is that there is no way to check on the equipment inside without opening the enclosure. This presents a [REDACTED] issue with our project because if the components fail for any unknown reason there will be no way to check inside for harmful chemicals before exposing [REDACTED] personnel to an unknown danger. This reason alone means a completely enclosed weatherproof enclosure is not going to be considered for the project design. The vented enclosure provides the same advantages and disadvantages as a completely enclosed one with the only difference of less protection against humidity and liquids due to the openings of the vents. The unknown hazard issue and humidity/liquid issue cause too many [REDACTED] and



equipment issues that a vented enclosure was not considered for the project. Process of elimination brought the project to having a windowed weatherproof enclosure. The windowed enclosure mitigates the hazard issue of the completely enclosed enclosure of unknown hardware failure. The windowed enclosure provides a way for an individual fixing the project to physically see if the project failed in a way that is safe to attempt to repair. In summary, the chosen IP66 rated and NEMA type 4 weatherproof enclosure will be windowed.

## **3.12.2 Dehumidifier**

The robustness of the overall design of the project is not just determined by the general protection from the outside environment. The robustness is also highly dependent on the mitigation of the humidity our project will be subject to due to the setting of where the project will be tested. Florida is known to have high humidity levels throughout the year and the project design constraints set by our sponsors require it to operate in this particular set of humidity levels. The project has electrical hardware components that can have their lifespan shortened by the humidity. This section will focus on two ways to mitigate this humidity through dehumidifying through either silica packets or filters on, or in, the enclosure.

### **3.12.2.1 Silica Packets**

One of the methods considered for handling the humidity inside the enclosure was putting silica packets inside of the enclosure to absorb moisture. Silica packets come in different sizes based on total silica gel mass. The masses range from 1 gram to 120 grams and the volumes that they can dehumidify range from 120 cubic inches to 8 cubic feet respectively. The design constraint the project has that was given was the components on-board should be able to fit in a 12-inch cube. The design constraint means the enclosure's volume cannot exceed 1 cubic foot or 1728 cubic inches. Matching up the volume restriction to the silica packets' dehumidifying volume restriction, the largest mass silica packet that would be needed for the project is 30-gram packets that are good for a 2 cubic feet volume.

The next consideration with silica packets is to know when they are saturated and need to be changed. There are two possible methods to determine if the packets need to be changed. One method is finding a manufacturer that provides silica packets that change color as they saturate. The second method is using an indicator strip that changes colors as the humidity percentage rises inside of the enclosure. The first method has the advantage of being an all-in-one design packet that will change colors when it is saturated by the humidity. The disadvantages to this method is that they are costly and has questionable accuracy. The second method of using an indicator strip has the advantages of being cheap and accurate. The downside to the method is that it is one more piece to change out when switching out the silica packets. In the end, the humidity indicator strips were decided to be used for the project. The humidity indicator strips will detect humidity ranges from 10% to 60% with clear color changes in between. The project's electrical components require the weatherproof enclosure to be in a humidity range

of 30% or below for nominal operation and to achieve an acceptable lifespan from the components.

### **3.12.2.2 Filters**

The other method considered to mitigate the issue of humidity inside of the weatherproof enclosure is by using filters that not only block dust but absorb moisture. The filters would use the natural airflow of the enclosure to block dust and absorb humidity to a certain point. The filters would need to be changed on a regular basis, much like air filters in most households. The advantages and disadvantages were not even considered with this method because it requires a vented weatherproof enclosure to be properly utilized. The weatherproof enclosure that was decided for use on the project was windowed and not vented.

## **3.13 PCB Design**

ABET requirements for the project desired a PCB, Printed Circuit Board, design be created. The use of a PCB in the project will be to create a device that will be a control system for the test object and a display for the inputs and outputs of the system. for the large-scale project. The design needed a suitable program to create the circuit and a board manufacturer to build the required circuit board. These were chosen based on comparison on what they offered and familiarity. The programs are decided on first because the files that they correct will be sent to the manufacturers after the circuit design is created.

### **3.13.1 Programs**

The circuit design programs that were compared for use in the PCB design are MultiSim and Eagle CAD. The important factors from both of these programs is that they provide the ability to create a BOM, Bill of Materials, file and have the ability to create a file to send to a manufacturer. MultiSim is program used by a majority of UCF faculty to teach students circuit design in classes such as electronics 1 and electronics 2. This provides MultiSim with the advantages of it being a program that most electrical engineering students know how to use, but also being readily available for circuit design while using computers on the UCF campus. Another advantage to MultiSim is that the program has an expansive library on useable circuit components. The library includes not only virtual components with customizable values, but real components from multiple different manufacturers. A disadvantage of the program is that if there is a need to use it at home the program has to be purchased for use first. Another disadvantage is that when the circuit design needs to be sent to a manufacturer the file containing the design needs to be converted to a different format before it is sent. The previous disadvantage could possibly lead to the file or design being either corrupt or inaccurate compared to the original circuit design file.

The other program, Eagle CAD, is a scriptable electronic design automation (EDA) application with schematic capture, PCB layout, auto-router, and

computer-aided manufacturing (CAM). Eagle has the same advantage as MultiSim with having a large library of components to create from a circuit. An advantage Eagle has over MultiSim is the ability to acquire the program for home use. The company that created Eagle allows students to use their software for free as long as a valid student email address is used. Another advantage is that Eagle can save a circuit design directly in to a file that can be sent to a manufacturer. One downside to Eagle is that it is an unfamiliar program, so there is a time constraint with having to learn how to use the program and make the files necessary for circuit design. In summary, after comparing Eagle CAD and MultiSim the desired PCB design software was decided to be Eagle CAD. This decision was made because it was an unknown program that could easily be learned, and the files created by it can be easily ported to a PCB manufacturer.

### **3.13.2 Board Manufacturers**

The next most important aspect of PCB design is choosing a manufacturer to print the circuit board to which the desired components will be mounted. There are three manufacturers that were taken in to consideration to make the PCB for the test object's control system and display device. The manufacturers are PCBWay, JLC PCB, and OSH Park. These three were chosen for because of cost, availability, and shipping time. PCBWay and JLC PCB are Chinese PCB manufacturing companies which keeps costs low for customers but affects shipping time negatively. OSH Park was chosen as the PCB manufacturer for the test object's control system and display device because it is based in the US, relatively low cost for 2 layer and 4 layer boards, and gives the choice of dropping in an Eagle CAD file to send to the manufacturer.

## **4.0 Related Standards**

The general standards that may be used during this project are the National Electrical Code and the UL508C standard (standard for power conversion equipment). The sponsor standards that may be used during this project are the Design Review Standard, the Hazard Analysis Techniques Standard and the Software Engineering and Configuration. Other standards being used are ITU-T G.9959 recommendation for Z-Wave devices, NEMA enclosure rating standard for weatherproof enclosures, and IEC standard 60529 for the IP Code rating for the weatherproof enclosure.

## **5.0 Project Hardware and Software Design Details**

For the initial process of the design and implementation will be to design the physical aspect of this system. One of the goals of the AP Project is to present several concepts to our sponsor, [REDACTED], for further discussions. These concepts had to be working concepts that would meet the initial requirements set forth by the sponsor. This includes, but not limited to, concepts on how to read the angular position and how to give the information to the PLC on the way-side.

## 5.1 Concepts A and B Presented to [REDACTED]

The AP Project team delivered two working concepts to our sponsor on February 28, 2018. Each concept could be designed to meet all [REDACTED] requirements that were set stated in the initial meeting between the team lead, Amber Haley, and the [REDACTED] representatives. The two concepts were discussed in a design review meeting format between the AP Project team and the [REDACTED] representatives.

### 5.1.1 General Concept A

This concept uses an encoder attached to the shaft of the test object to read the test object's linear angular position. Once the angular position is obtained, the encoder feeds that information to an analog to digital converter. Then the converter gives the data to an onboard transmitter. The transmitter sends the data wirelessly to an off-board receiver. Once the data is received, the data will bounce through routers until it reaches its final receiver near the PLC. The final receiver feeds the data into the PLC. In Figure 3 shows a block diagram of concept A's set-up.

#### Wireless Transmission of Data

We are considering using Z-Wave technology that works similarly to IEEE 802.11 standardized routers, but instead use the less frequently used 902-928 MHz ISM bandwidth to transmit data. A reason for doing so is because it will have little to no interference coming from modern devices using the 2.4 Ghz - 5 Ghz ISM bandwidths most of the afore mentioned 802.11 routers use. Another reason to use Z-Wave and it's 900 MHz bandwidth is that because it's a longer wavelength than 2.4 GHz, let alone 5 GHz, it has an extended range of use compared to those two commonly used bandwidths.

#### Power

The off-board components are powered by a power supply with an in-line breaker and a voltage regulator. The on-board components are powered by a battery pack which will last about 30 hours before needing recharge.

#### PLC Program

The PLC program will take the information received and compare it to the following conditions:

1. Is the test object stuck
2. Is the test object unstuck
3. Is the test object in range
4. Is the test object out of range

Once the parameters are set, the program will do one of the following:

1. Nothing
2. Issue a [REDACTED] stop request
3. Retain the information to compare with the next packet of data received

## On Board Encoder Concept

- Black line = power lines (PL)      — Blue line = wireless data (WD)
- Orange line = data lines (DL)

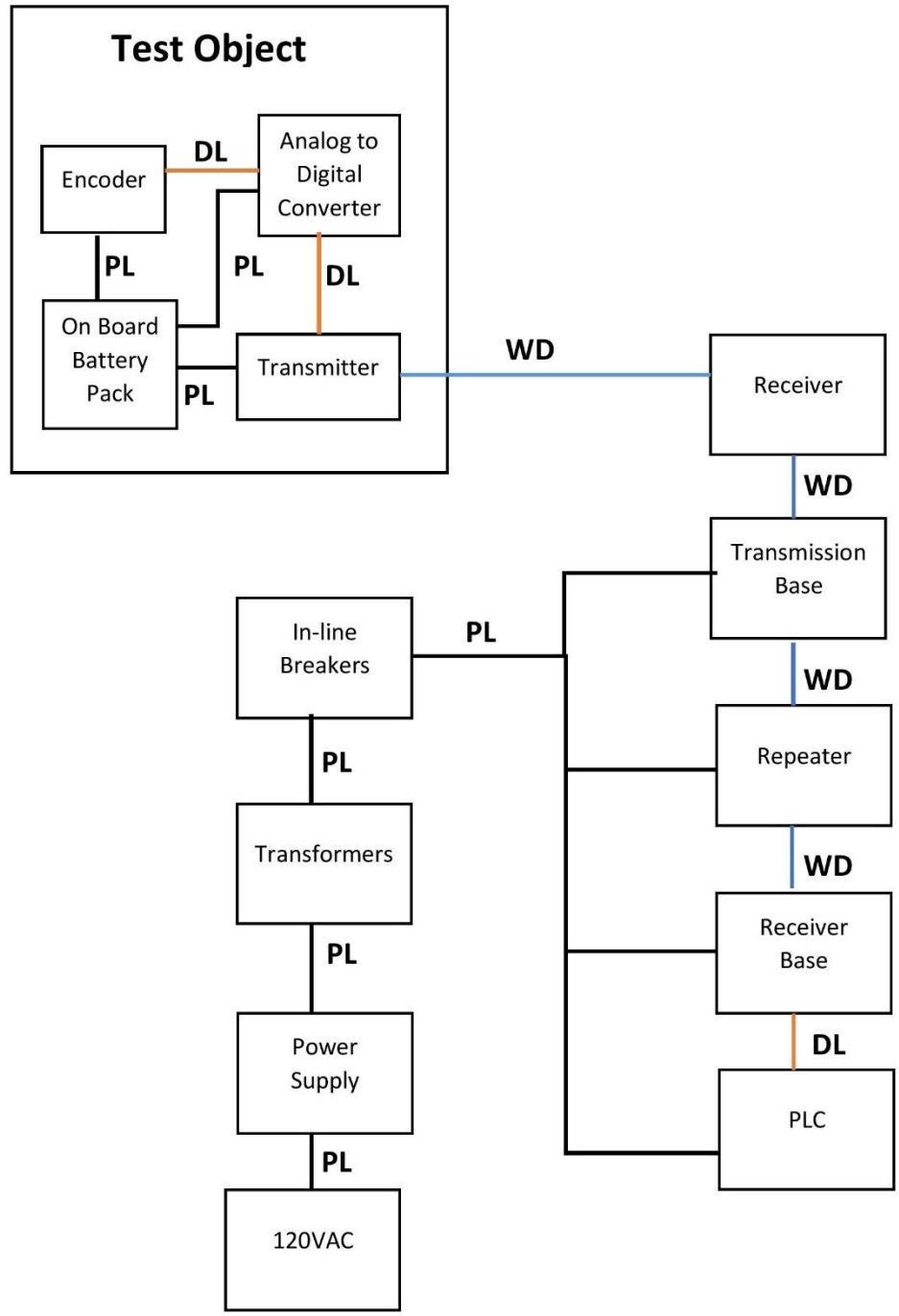

**Figure 3: Concept A Block Diagram**

## 5.1.2 General Concept B

This concept uses a non-contact linear position sensor with one or two independent outputs which operate using Hall Effect technology. This means the only on-board component will be the magnet needed for the sensor to read its position. Once the angular position is obtained, the data is sent to an analog to digital converter. The converter sends the data to the PLC. In Figure 4 shows the block diagram of concept B's set-up.

### Power

All powered components are off-board therefore everything will be powered by the power supply with in-line breakers and transformers.

### PLC Program

The PLC program will take the information received and compare it to the following conditions:

1. Is the test object stuck
2. Is the test object unstuck
3. Is the test object in range
4. Is the test object out of range

Once the parameters are set, the program will do one of the following:

1. Nothing
2. Issue a ████ stop request
3. Retain the information to compare with the next packet of data received

## Off Board Magnetic Sensor Concept

- Black line = power lines (PL)
- Orange line = data lines (DL)

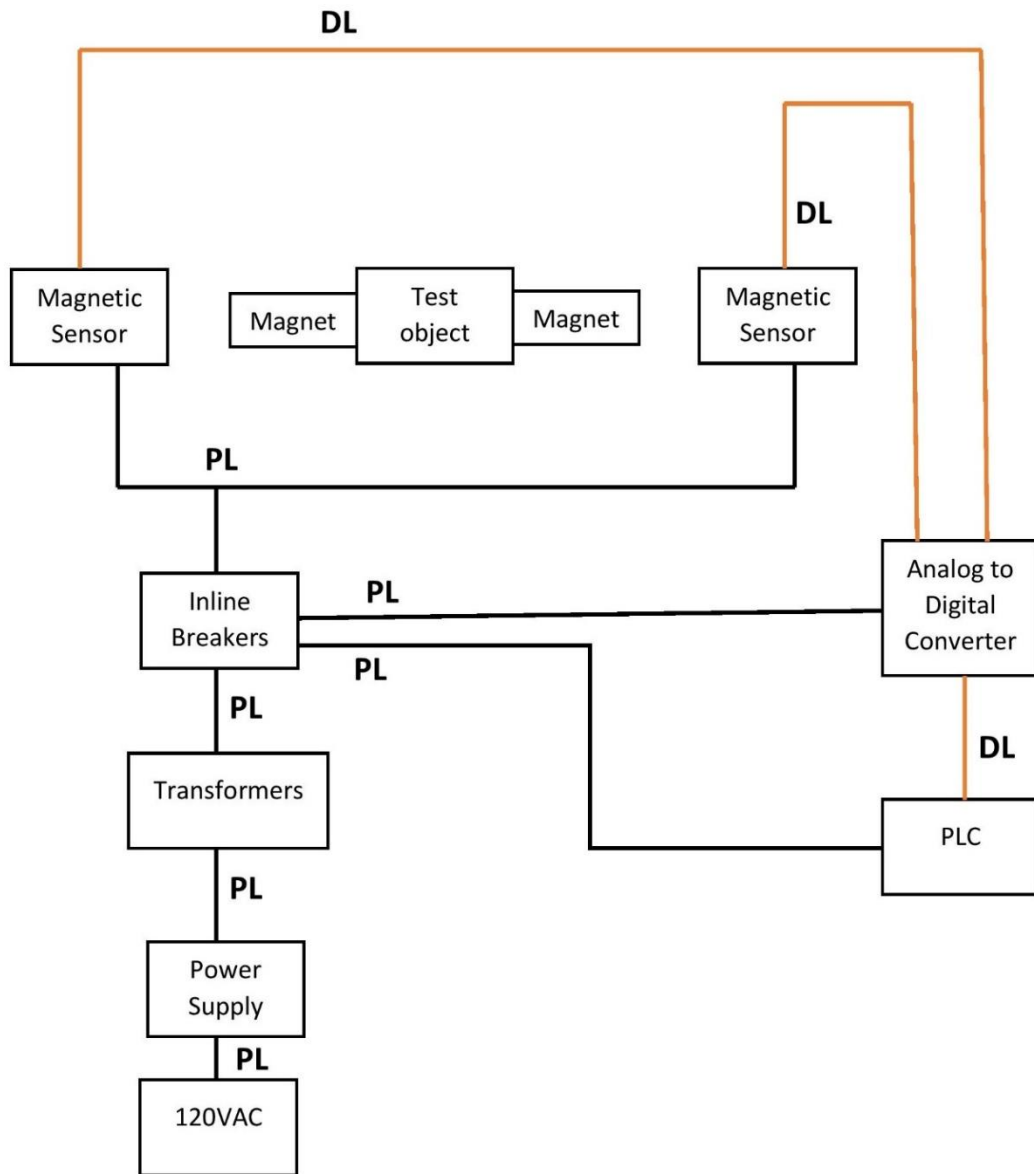

Figure 4: Concept B Block Diagram

### 5.1.3 Concept Chosen Conclusion

On February 28, 2018, we presented two design concepts to [REDACTED]. We have included both design concepts (see concept A and concept B above). The conclusion of our concept design review with our sponsor was to modify the requires as follows. The software was originally going to determine if the test object was in a stuck position or in a not stuck position. This is no longer a requirement. The sponsor is most interested in the angular position, so the stuck and not stuck information is what we call “a nice to have.” Originally the design team was going to put the test object in motion, possibly around a [REDACTED] track, to ensure that the signal was being captured along the track side at different polling points. There was going to be 3-4 polling points that attained the angle along the track. [REDACTED] is more concerned with ensuring the concept works and therefore stipulated that the test object will be stationary for prototype testing and concept provability.

When the original design was presented to the AP Project team, the sponsor asked for angular position of a rotating object but no information on along which axes the test object was rotating. The sponsor clarified that the angular position was to be a 180° linear direction along the x-axis. Originally the requirement was for the angular position to determine if the test object was in range or out of range. This requirement remains but better clarification was given on what is considered in range or out of range. The in-range angles are to be 0°- 60° in both directions and the out of range angles are to be 61° - 90° in both directions. When the concepts were presented, the question of how we can verify the signal with the angular data was sent was asked. Upon deliberation, the sponsor added a requirement of a signal received display. The sponsor also wanted to know how to verify that the angle going into the encoder was the angle coming out of the encoder, basically how to ensure the encoder is not giving false angles. They then added an angular position display as a requirement. The sponsor wanted to ensure that if the test object was in an abnormal operation that the [REDACTED] stop request issued. [REDACTED]. They added a [REDACTED] stop request display as a requirement. After discussing both design concepts, the sponsor decided on Concept A, wireless transmission of angular position. They were most interested in transmitting wireless data from on-board a test object to a way-side receiver.

Since the test object is to be in a stationary position for testing purposes, the sponsor requested that the extra equipment be removed from the design. Specifically, the transmission base, the repeater and the receiver base. They wanted the receiver to be hardwired directly to the PLC. This design has a battery pack in the on-board enclosure, so the sponsor made a few additional requirements in regard to the battery. A low battery display was added as a requirement. They want to make sure that there is some sort of indication the battery is low for two reasons. It allows them to spot if a battery is going bad and not holding a charge and it also helps with not adding additional work to the [REDACTED] staff if the battery does not need charging yet. The sponsor added



a requirement of a standard voltage for the battery pack. If the battery is hard to get or of an unusual voltage, it makes acquisition of parts cumbersome. Lastly, they added a requirement of a battery life of 1 day. Realistically, they were looking at about 20 hours. Normal operating hours of a [REDACTED] would not exceed probably 18 hours so to err on the cautious side, they require 20 hours of battery life.

## **5.2 Component Selection**

After extensive research on all the possibilities for each component needed the parts have been chosen. Each component listed below was the best choice for this project. Once the type of part needed next was to find who can supply the part and in the least amount of time for shipping and least cost. The following components below will have the specification, and which supply we choose to go with. For each supplier we did try to stick with a distribution in the United States to help with to minimize time if shipping back parts is needed.

### **5.2.1 Battery**

The final battery that was decided for this project was a 22000mAh battery at 11.1 volts designed by MaxAmps. The battery is a lithium polymer that can tolerate up to 140°F until thermal runaway occurs. Below 14°F, the shorter the run times which slows down the reaction within the battery, which can cause failure. The battery has a 40C rating for its discharging and a 5C fast charge capability. The power wires that come with the battery is a 12-gauge wire that will have a XT60 connector to help with anti-spark when unplugging and plugging in the battery to the microcontroller. With the capacity chosen will give about 30 hours of run time before recharging will be needed or replacement. In figure 14, shows the battery that will be used. The Table 11 gives the rest of the specifications and ratings for this battery from this supplier that we also took into consideration when deciding on this supplier.

(MaxAmps, n.d.)



**Figure 5: MaxAmps 11.1V Battery (permission)**

Specification	Rating
Type	Lithium Polymer (LiPo)
Cell(s)	3S – 3 cells in series
Capacity	22,000mah
Volts	11.1 V
Charge Capability	5C
Rating	40C
Warranty	Lifetime
Wire	12awg
Charging Connector	JST-XH
Plug	XT60

**Table 11: LiPo Battery Specification from Supplier**

## 5.2.2 Voltage Regulator

The voltage regulator that was picked is a DROK LM2596. The input voltage can range from 4 to 40 volts and make an adjustable output that can range from 1.25 to 37 volts. The output current for this regulator 2amp with a 3-amp max. Accuracy is always key in designing projects, so this voltage regulator has an accuracy of +/- 0.1 volt. As seen in Figure 6 below. The Table 12 also give the rest of the specifications from the supplier that we also took into consideration.

(Droking, 2018)



**Figure 6: DROK LM2596 Voltage Regulator (pending approval)**

Specifications	Rating
Input voltage	5V to 36V DC
Output Voltage	1.25V to 32V DC
Output Current	5A Max
Output Power	75W Max
Operating temperature	-40 C to +85 C
Operating frequency	180KHz
Conversion efficiency	Up to 96%
Short Circuit protection	Yes
Overtemperature protection	Auto shut off output after over temperature
Installation	4 - 3mm screws
Wiring	Solder terminals

**Table 12: Voltage Regulator Specification from Supplier**

## 5.2.3 Balance Charger

To keep the lithium polymer battery charged at the right amps a SKYRC iMAX B6AC V2 was picked, as seen in the Figure 7 below. The input voltage for this is between 100 to 240 volts, which means it can be plugged into a wall outlet in a house. The display is a 2x16 LCD screen with a blue backlight to be seen even at night. The SKYRC iMAX has a built-in timer that will automatically shut off the charging. This charger also can range up to a 6-cell battery with 10 different charge/discharge profiles. If needing to store a battery this charger also has a discharge ability to keep for safe storage. Other capabilities of the iMAX is a temperature probe socket so if the temperature limit has been reached, it will shut off and can be connected to a smart phone to monitor the charging if not around by a monitor module that can be separately bought. The Table 13 is the rest of the specifications from the supplier that we also took in consideration.

(SkyRC Technology Co., 2018)



**Figure 7: iMAX B6AC v2 balance charger (pending approval)**

Specification	Rating
AC Input voltage	100V to 240V
DC Input voltage	12V
Max Charge	50W
Max discharge	5W
Charge current range	0.1A to 0.6A
Discharge current range	0.1A to 1.0A
Ni-MH/ NiCd Cells	1S to 15S
Li-ion/ LiPoly Cells	1S to 6S
Pb Battery voltage	2V to 20V
Dimensions	135 x 144 x 36 mm
Weight	632g

**Table 13: Battery Charger Specification from Supplier**

## 5.2.4 Battery Monitor

The battery monitor for the project will display Voltage, Amperage, Wattage, and Amp-Hours for battery maintenance purposes. The battery monitor, Figure 8, is a Powerwerx Watt meter, DC Inline Power Analyzer. The source side will take in the voltage from the power source and the load side will go to powering the microcontroller. This is a feed through device, so the power going in is the same as the power going out. The Watt Meter also has the ability to have an auxiliary battery to be able to detect voltages under 5 volts. The screen is backlit, so if any maintenance is needed to be done after dusk the screen provides the light needed to check for issues.

(Powerwerx, 2018)



*Figure 8: Powerwerx Watt Meter*

## 5.2.5 Encoder

We were able to locate a miniature absolute magnetic regular shaft encoder from US Digital show in Figure 9. This encoder produces an analog output with a 10-bit resolution. This means each output corresponds to  $.351^\circ$  which will exceed the accuracy needed for this design. The miniature encoder is .48" in diameter and is so small, the weight is negligible. The encoder is small, but robust in nature.

(US Digital Products, 2018)



*Figure 9: US Digital Miniature Absolute Magnetic Shaft Encoder*

## 5.2.6 Encoder Coupling

The regular shaft encoder is designed with a solid shaft to be inserted into a bore that accepts that size shaft. This project is to prove a concept that could be used in the future, so it is not known if the future shaft will have a bore or not. Taking this into consideration, we decided to include an encoder coupling. This coupling is designed to fit on top of the encoder shaft and connect it to another solid shaft. This gives the design more flexibility of what type of shaft as well as the diameter of the shaft that can be used in the future. There are a few different types of couplings to choose from. There are magnetic and nonmagnetic, rigid or flexible just to name a few. We felt a magnetic coupling could possibly interfere with the encoder information so to err on the cautious side, we chose a nonmagnetic coupling. Rigid or flexible couplings would both work for our application but to increase the flexibility of the design, we chose a flexible coupling. The flexible coupling will help with run-out putting excessive loads on the encoder. The encoder has a  $\frac{1}{4}$ " shaft so one side of the coupling must fit a  $\frac{1}{4}$ " shaft. There are several other sizes to pick from for the other side of the coupling so for simplicity reasons, we chose a  $\frac{1}{4}$ " bore size. We located a  $\frac{1}{4}$ " to  $\frac{1}{4}$ " flexible coupling from Encoder Products Company, as shown in Figure 10, for a reasonable price.

(Encoder Couplings , 2018)



*Figure 10: Encoder Company Flexible Coupling*

## 5.2.7 Microcontroller

The microcontroller that was decided on for use was the Raspberry Pi 2 Model B as shown in Figure 11. There will be two of these in use for the overall project and one of them will be used to program the PCB for the test object's control system and display device. The first Microcontroller will have a push-button, a Z-Wave module, and an encoder attached to it. The first MCU will also be powered by the on-board battery. The second will be powered by a regular ac to dc power supply with a microUSB attachment. The second will have a Z-Wave module and two wires running from two different IO pins to the PLC. The MCUs maximum

operating voltage is 5 Volts and Amperage of 2 Amps. The microprocessors on them operate at 900 MHz and have a 1 GB of RAM on-board for volatile memory use.

(Allied Electronics & Automation, 2018)



*Figure 11: Raspberry Pi 2 Model B*

## 5.2.8 Z-Wave Module

The Z-Wave.Me RaZberry, Figure 12, is the module that will be on both of the microcontrollers that enable the ability for the devices to communicate wirelessly. The module has a 10-pin female connector attached to it that allow it to communicate with the microcontroller it is attached to. This device is the reason why the Raspberry Pi 2 was chosen as the desired microcontroller. The other microcontrollers did not offer a way to use the specified wireless communication method. The module is powered by the MCU, has a 32 KB EEPROM to flash a program to, and is low-power compared to the microcontroller.

(Z-Wave.Me, 2017)



*Figure 12: RaZberry Z-Wave Plus GPIO Card*

## 5.2.9 Push Button

This Adafruit 16mm illuminated pushbutton, Figure 13, was chosen for the zeroing button that will be wired to the microcontroller. The function this button serves is shorting a GPIO pin with a 3.3 Volt pin on the microcontroller. This will allow the microcontroller to initialize the encoder value being fed in to it. The LED on the pushbutton does not need to be powered for it to work but is an added benefit if it ever needs to be utilized. This button will always be operated manually at the start of the test procedure for the project.

(Adafruit, 2018)



*Figure 13: Illuminated Pushbutton*

## 5.2.10 PLC

When we approached [REDACTED] about our choice of PLC type, size and manufacturer, we were told they have some spare Allen Bradley PLCs in their lab and would allow us to use one of theirs for cost effective purposes. After comparing the different CPU modules available, we chose the Allen Bradley SLC 5/05 1747-L553. The SLC 5/05 has a quicker scan time than older models and faster bit execution. The L553 is a 64K memory that will be more than enough for our programming needs. Once the CPU was chosen, we had to verify the proper power supply module was available for the SLC 5/05. Fortunately, the proper power supply was on hand which is an Allen Bradley 1746 SLC System, Power Supply - Rack Mount, 120/240 VAC, 5A. This means we can plug it directly into a 120V wall outlet without the need for a power supply in between. Next was deciding what I/O modules were needed. The input coming into the PLC is a digital signal from the microcontroller that means the input card must be digital. There is going to be four inputs into the card so a minimum of an eight-point input card was needed. The input points in an Allen Bradley are packaged in eights. The input is only supposed to receive information and does not need to power any externals therefore a sinking module was the best option. The 1746-IB16 input module was available which covers all the requirements. The 1746-IB16 is a sinking digital module with sixteen available input points. Even though we need only eight points, it is always a good idea to have spares on hand in case the design requires more in the future. Lastly an output module was needed. The PLC would be powering the external lights as outputs, so we needed a sourcing module. There are six



different lights that need to illuminate therefore we needed at least an eight-point output module. The signal being sent to the light is to be either on or off, which is a digital signal, so we needed a digital module. We were able to locate a 1746-OB16 output module in the lab. The 1746-OB16 output module is a digital sourcing module with sixteen available output points. Once again, even though only eight points are needed, it is always good to have spares on hand. The chassis that was available in the lab has slots for the power supply, the CPU, the input module, the output module and one other module. Purely for aesthetic purposes and possible future use, we decided to add in a communications module to complete the chassis. The module available is a MVI46-MCM which we will not be using for this project.

### 5.2.11 Weatherproof Enclosure

The L-Com 12x10x5 inch weatherproof windowed NEMA enclosure, Figure 14, was chosen as the desired enclosure for the project. The window on the front allows [REDACTED] personnel to be able to monitor the battery without opening the case. The enclosure also allows personnel to notice any visible hazards within the case before opening it for maintenance. The window also provides less of an impact on wireless attenuation compared to the molded FRP, Fiberglass Reinforced Polyester. The total volume of the inside of the enclosure is 600 cubic inches. The components that will be going inside of this enclosure will suitably fit inside it without any space constraint issues.

(Infinite Electronics International, Inc., 2011)



**Figure 14: Weatherproof Windowed NEMA Enclosure**

### 5.2.12 Silica Packets

The silica packets that were chosen to satisfy the projects needs for humidity control is the 5-gram silica gel desiccant package. A 30-pack of these packets is shown in Figure 15 and there will be two in the enclosure listed above at any time. Since the enclosure is 600 cubic inches and the 5-gram packets are rated for 600

cubic inches. Doubling on this recommendation was a decision made because of the intensity of Florida's Humidity.

(Dry & Dry, 2015)

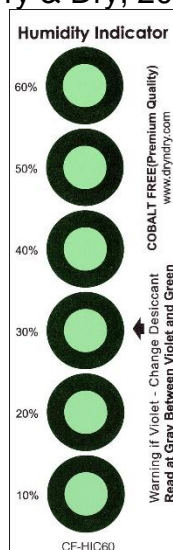

**Figure 15: 30 pack of 5-gram Silica Gel Packets**

### 5.2.13 Humidity Indicator

The Dry & Dry Premium Cobalt Free Humidity Indicator cards, Figure 16, are the cards that will be inside of the enclosure alongside the silica gel packets. These cards will be able to be seen through the enclosure's Lexan window, so that way the enclosure does not need to be opened to check these cards. This is beneficial because the silica packets work best in a sealed environment. These cards change from green to violet when the humidity reaches 30% or more inside of the enclosure. The card also has an arrow indication as to when the silica gel packets are needed to be changed. This is helpful for [REDACTED] personnel because they will not need to remember a specific value to know when to change out the packets and indicator cards.

(Dry & Dry, 2015)



**Figure 16: Dry & Dry Humidity Indicator card**

## **5.3 Printed Circuit Board (PCB)**

To satisfy UCF ABET requirement of course the project will be scaled down and include a PCB, printed circuit board, that will serve the function of a test object's control system and display device for the project. The test object's control system and display device will have a controllable motor with a shaft that the encoder is on, two LCDs, a battery to power the PCB, and a flashed EEPROM to interpret data. The motor will be controlled by a potentiometer to make the shaft change positions at a desired rate. The encoder will be connected via coupling to track the movement of the shaft. An Input LCD will be displaying the angle being applied to the motors shaft. An output LCD will be displaying the angle determined by the encoder. An optional method to applying the LCDs is to acquire one that can display both sets of data. All of this is powered by an off-board battery that is attached to a load terminal on the PCB.

### **5.3.1 PCB Specifications**

The specifications of the PCB are being able to power a motor, an EEPROM, and a set of LCDs. The PCB also needs to be able to communicate data between a potentiometer, a motor, an EEPROM, and a set of LCDs. Lastly, the PCB should be able to determine if the input data matches the output data by way of a program flashed to the EEPROM.

### **5.3.2 Soldering Components**

With using a printed circuit board, the components will have to be solder on to the board. For soldering there are two different ways to the components. The first way is to use soldering wire, while the other way is using a soldering paste. These two ways will both have their disadvantages and their advantages. Another characteristic in solder is if you want lead-free or lead which is an important aspect to take in consideration because of the health issues with lead.

#### **5.3.2.1 Soldering Paste**

In general, solder paste is a powdered metal distributed in a thick flux. Using the flux is to be, small amount of time, as adhesive. This will hold the components being soldered, once it heats it melts the metal and becomes a strong joint. The solder paste is a gray color. Stencils are a good guide when using a soldering paste. The stencil is cut to create the openings for the on-board components. Using soldering paste would be good for component with a lot of pins.

#### **5.3.2.2 Soldering Wire**

Another way to solder the components onto a PCB is to use solder wire. The advantage of using this is that it can be a faster way to solder if there are fewer components and it is a cleaner process than soldering paste. When the soldering iron is heated up allowing the solder wire to wet the top of the iron for tinning.

Taking the soldering iron to the PCB to heat up, the solder wire will be touched against the soldering iron that will allow the solder to melt and stick to the PCB. Once the time has elapsed to allow for cooling, the component will then be adhered to the PCB. In good soldering work acknowledgement is by the appearance of the ramp that is on the components pins.

## 5.4 Software Development Process

The plan for all software development shall employ software engineering “best” practices in verification and validation, configuration management, peer reviews, project tracking and software quality assurance. Figure 17 shows a general flow of how the software will be designed and Figure 18 explains how we are ensuring that the software is meeting design, budget and time requirements. Microsoft Project will be used to develop and maintain the AP Project master plan and schedule.

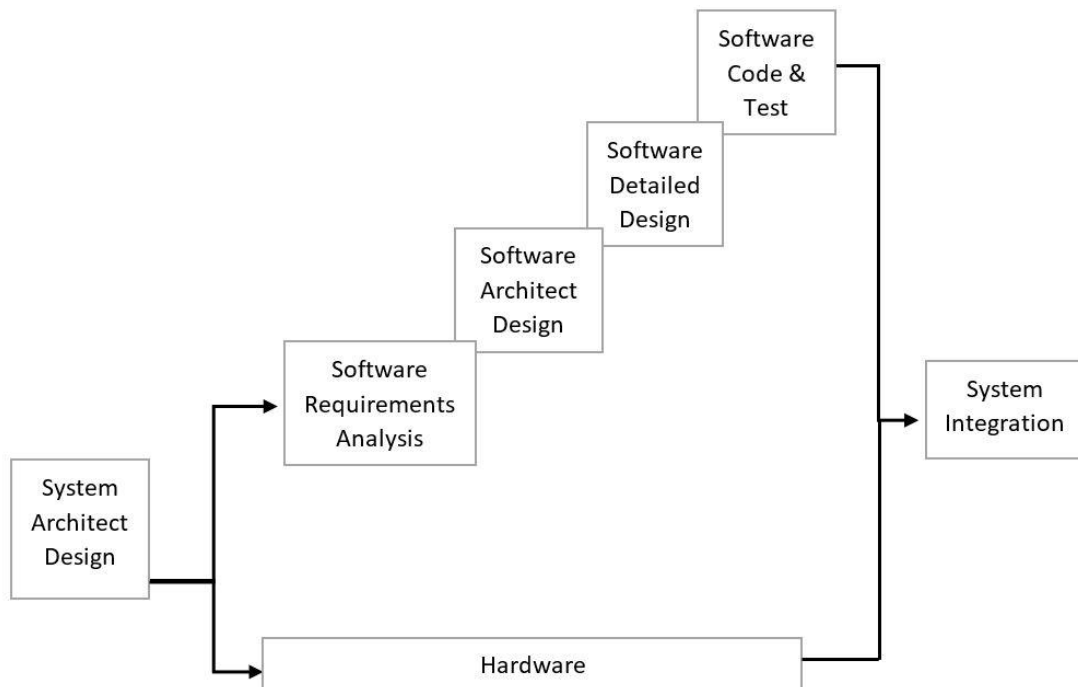

**Figure 17: Software Block Diagram**

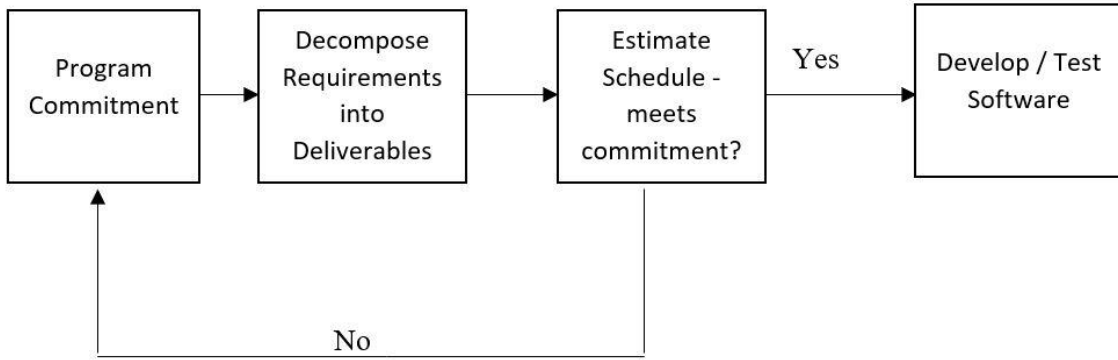

**Figure 18: Software Development Planning**

A copy of all software versions will be kept and are available upon request. A record of all software revisions including additions, modifications and deletions will be kept via an update chart shown in Table 14. The update chart will be available upon request.

Version #	Date	Section	Add/Delete/Modify	Description

**Table 14: Software Update Chart**

## 6.0 Project Prototype Construction and Coding

This section will cover the process that will be applied when constructing the prototype of the project. The subjects being covered are hardware fabrication, software fabrication, and coding. Hardware fabrication will cover the block diagram of the project, integrated circuit designs, assembly drawings, on-board housing assembly details, and way-side housing assembly details. The software fabrication will cover the software for the on-board and way-side housing assemblies. Lastly, coding will cover the microcontroller, PLC, and PCB.

### 6.1 Hardware Fabrication

The importance of diagrams and drawings in a design project is tremendous. The diagrams and drawings are a visual way of conveying how the entire system functions. This mostly consists of the hardware portion of the project, but we did include the software block diagram to show how the software will be developed in the future. The idea is to start at a high level, really simple block diagram, then work down further and further adding additional detail in each drawing or diagram.

The last drawing will be the schematic which shows the details of how each component wires to the other.

## 6.1.1 Hardware Block Diagram

The general concept, as illustrated with Figure 19, is that there will be on-board components that send wireless data to way side components. The on-board components and way-side components will work together to create an entire system of checks and balances. The on-board box is physically on the test object and the way side box can be located anywhere not on the test object such as the side of a track XXXXXXXXXX.

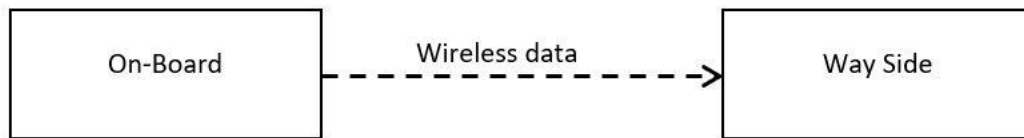

*Figure 19: System Block Diagram*

## 6.1.2 Hardware Integrated Circuit Designs

The ICD in Figure 20 begins to look inside the boxes listed in the block diagram in Figure 19. The ICD shows the different sections of the on-board configurations and the way side configurations. In visual terms, you easily see how many different sections are being encompassed in the overall design. The ICD also lists the wire sizes of the wires between the different sections and shows the flow of data and power.

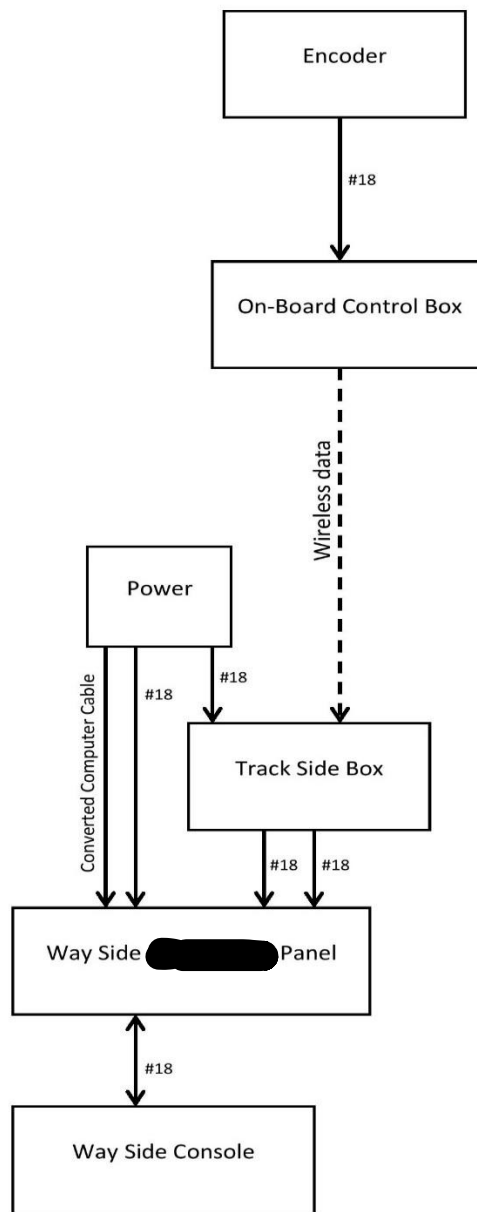

**Figure 20: Integrated Circuit Design**

### 6.1.3 Hardware Assembly Drawings

An assembly drawing takes each box from the ICD in Figure 20 and begins to dissect it. Each ICD box will have an assembly drawing as shown in Figure 21 for the encoder box, Figure 22 for the on-board control box, Figure 23 for the track side box, Figure 24 for the power box, Figure 25 for the way side control panel box and Figure 27 for the way side console box. The assembly drawing takes pictures of the components inside each box and lists out the part number for each

component, how many of each component is needed, the manufacturer of the component and a general description of the component. Some boxes have so many components that a “detail” accompanies the assembly drawings which gives a bigger snapshot of what is inside the box as shown in Figure 26 for the way side control panel detail A and in Figure 28 for the way side ████ control panel detail B. The assembly drawings coupled with the schematics would allow a third-party vendor to be able to build each box from the ground up.

1	3	CA-MIC3-SH-NC	3-Pin Micro Connector / Unterminated, Shielded Cable	US Digital
1	2	MA3-A10-250-N	Miniature absolute magnetic shaft encoder	US Digital
1	1	161307	¼" to ¼" flexible encoder coupling	Encoder Products
QTY	ITEM NO.	PART NUMBER	DESCRIPTION	MANUFACTURER

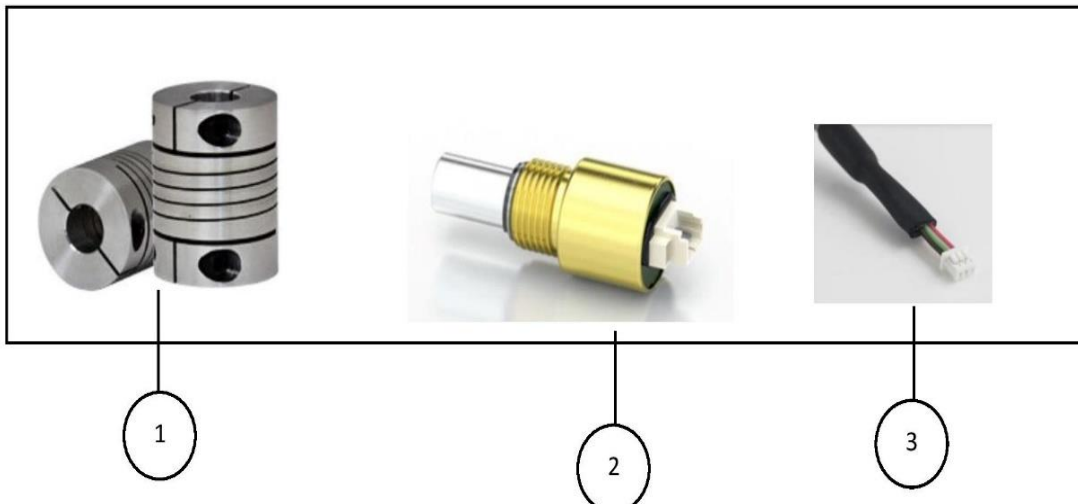

**Figure 21: Encoder Assembly Drawing**



1	9	T5875DV	Raspberry Pi Micro USB Power Supply 5V1 2.5AWhite	Raspberry Pi
1	8	ZME_RAZ_US	Z-Wave transceiver	Z-Wave.Me
1	7	1477	16mm illuminated push button	Adafruit
1	6	70465426	Raspberry Pi 2 Microcontroller	Raspberry Pi
1	5	FAZ-C2/1-NA-SP	2 amp circuit breaker	Eaton
1	4	DROK LM2596	Step down voltage regulator	DROK
1	3	WattMeter-Bare	Battery monitor	Powerwerx
1	2	XT60	Male and female connector plug for battery	Amass
1	1	LiPo 22,000 3S 11.1v Battery Pack	11.1V Lithium Polymer Battery	Max Amps
QTY	ITEM NO.	PART NUMBER	DESCRIPTION	MANUFACTURER

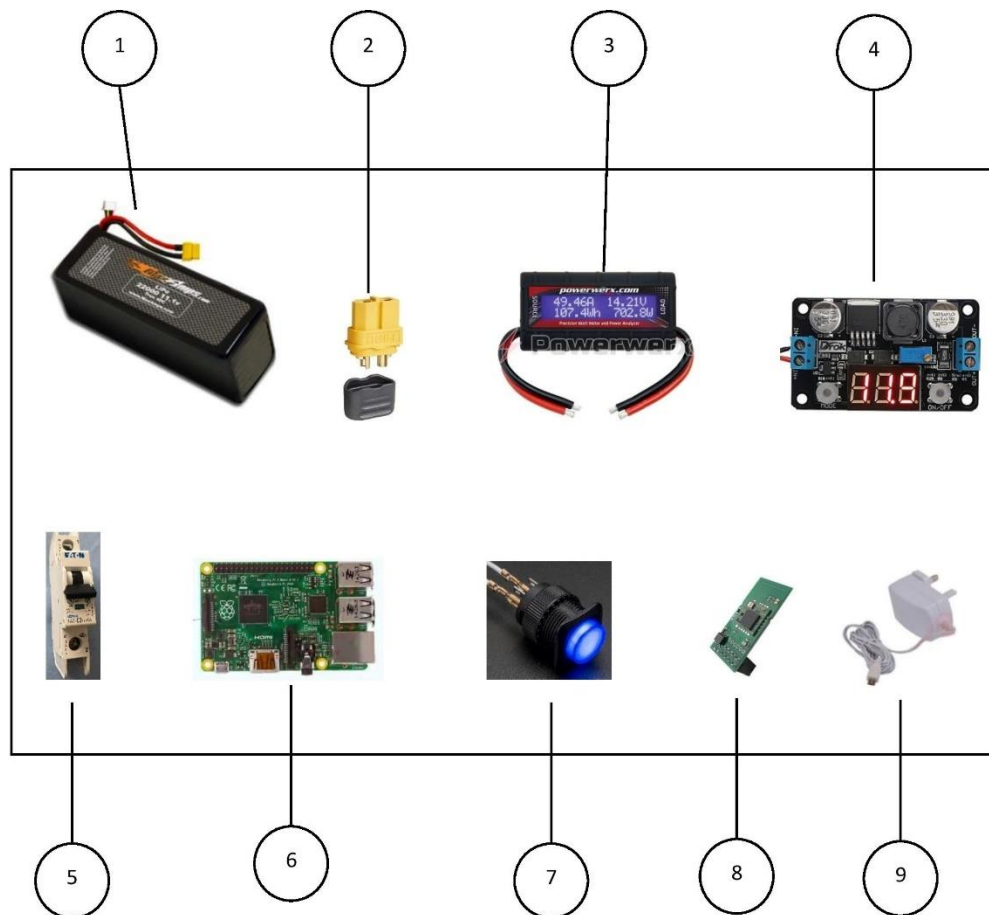

**Figure 22: On-Board Control Box Assembly Drawing**

1	2	ZME_RAZ_US	Z-Wave transeiver	Z-Wave.Me
1	1	70465426	Raspberry Pi 2 Microcontroller	Raspberry Pi
QTY	ITEM NO.	PART NUMBER	DESCRIPTION	MANUFACTURER

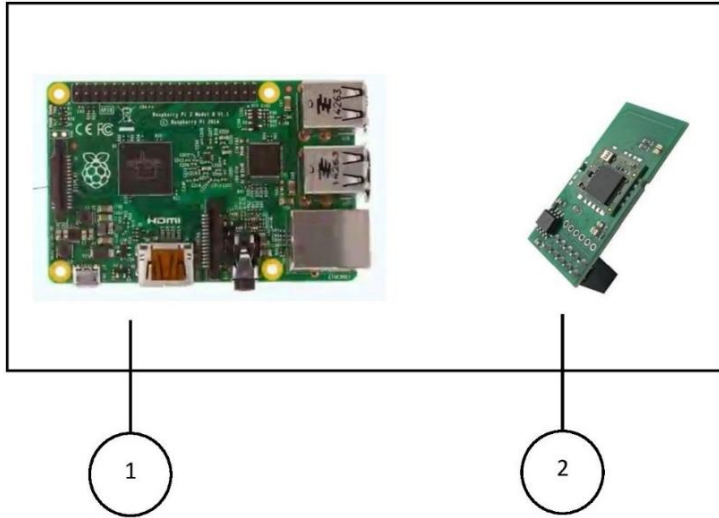

**Figure 23: Track Side Box Assembly Drawing**

2	4	None	3/14 AWG converted computer wire with 3 pronged plug end	Any
1	3	T5875DV	Raspberry Pi Micro USB Power Supply 5V1 2.5AWhite	Raspberry Pi
1	2	SDN10-24-100C	Power Supply; AC-DC; 24V; 10A; 85-264V In; Enclosed; DIN Rail; PFC; 240W; SDN Series	SolaHD
1	1	None	Standard 120V wall outlet	Any
QTY	ITEM NO.	PART NUMBER	DESCRIPTION	MANUFACTURER

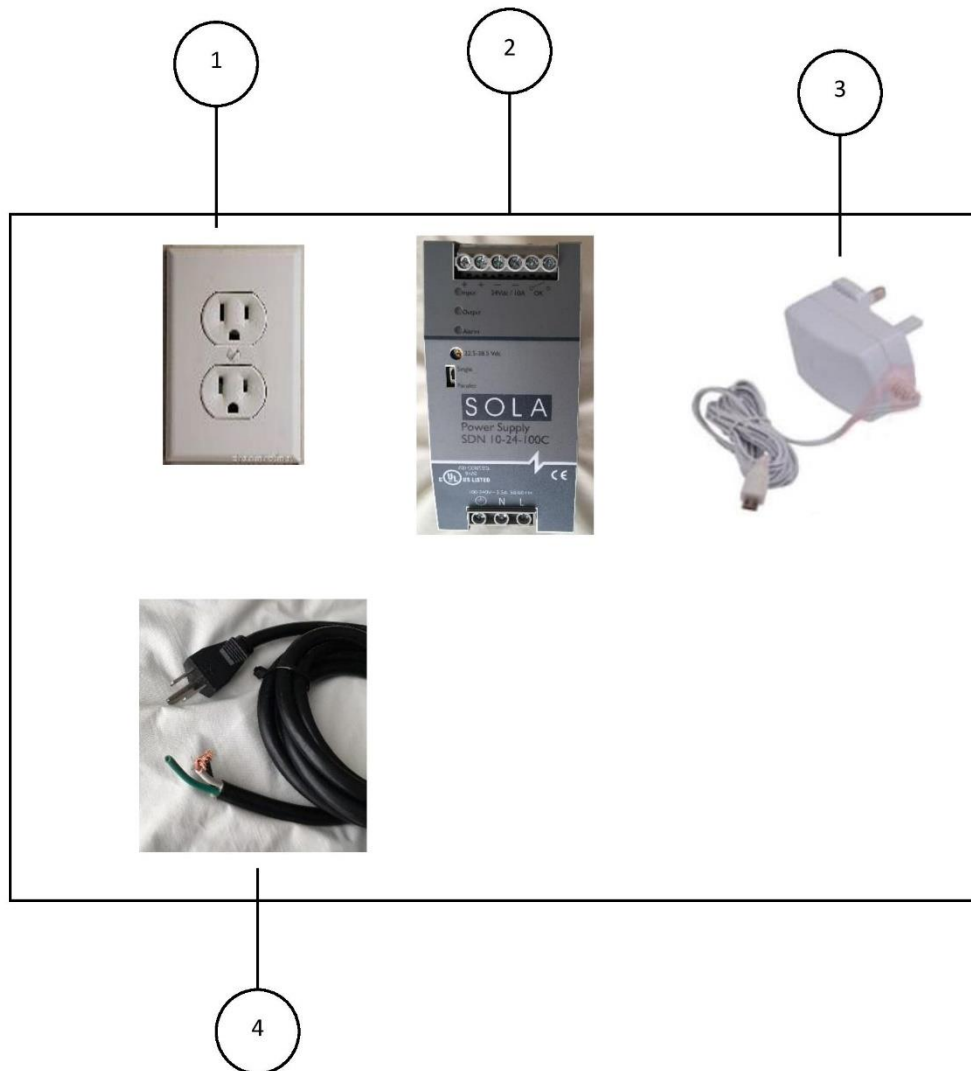

**Figure 24: Power Box Assembly Drawing**

4	11	280	Two to One Terminal Block	Wago
1	10	1746-OB16	1746 SLC System, 16 ch-DC Output Module For Programmable Controller (sourcing)	Allen Bradley
1	9	1746-IB16	1746 SLC System, 16 ch-DC Input Module For Programmable Controller (sinking)	Allen Bradley
1	8	MVI46-MCM	Communications Card – Not Used	Allen Bradley
1	7	1747-L553	1746 SLC System, SLC 5/05 Controller - 64K Memory	Allen Bradley
1	6	1746-P2	1746 SLC System, Power Supply - Rack Mount, 120/240 VAC, 5A	Allen Bradley
1	5	1489-A	Circuit Breaker	Allen Bradley
6	4	None	Blue Bottom Layer One to One Terminal Block	Wago
4	3	280	End Barrier	Wago
4	2	249	End Anchor	Wago
17	1	280	One to One Terminal Block	Wago
QTY	ITEM NO.	PART NUMBER	DESCRIPTION	MANUFACTURER

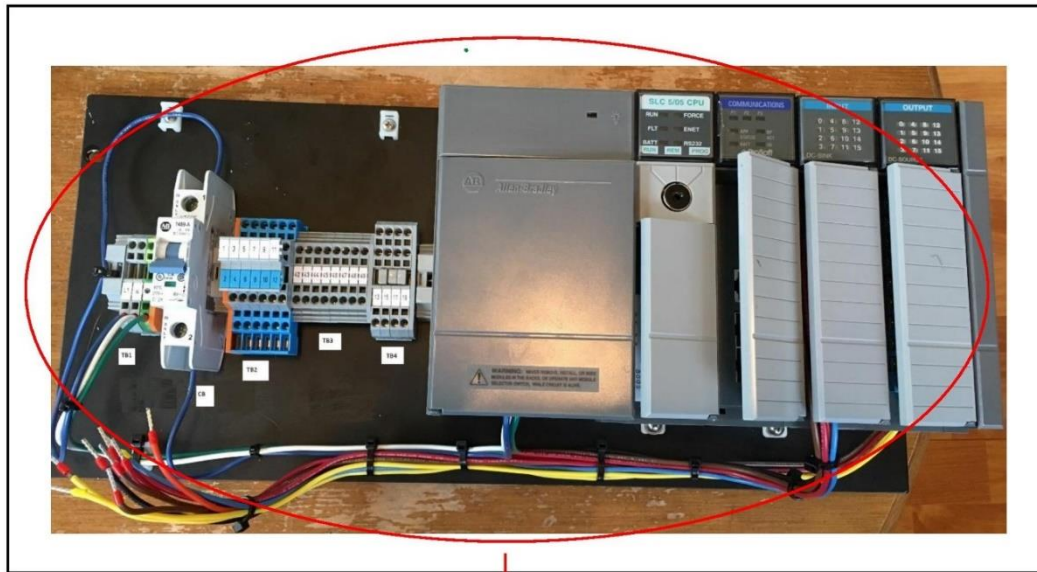

SEE DETAIL "A"

**Figure 25: Way Side Control Panel Assembly Drawing**

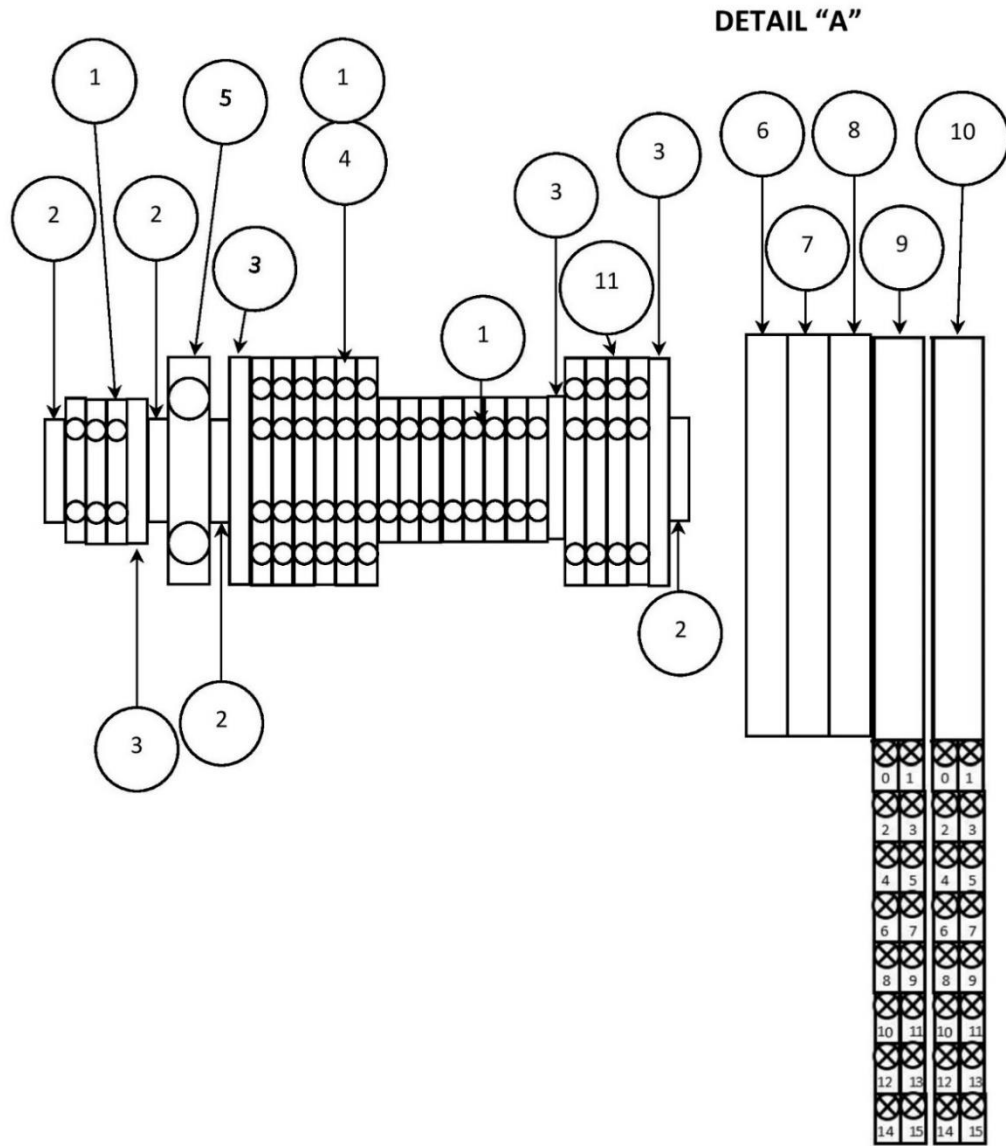

**Figure 26: Way Side ████ Control Panel Detail "A" Assembly Drawing**

12	4	800F-N3Y	800F Pilot Light Illuminator	Allen Bradley
12	3	800FD-P5N3	800F Pilot Light - Rd. Plas. Monolithic (IP66, 4/13, IP66), Yellow, Integrated LED, 24V AC/DC (Yellow Top Button)	Allen Bradley
12	2	800F-Q10	22.5mm PB No Latch, Spring-Clamp Contact Block, 1 N.O. (Green Spring)	Allen Bradley
12	1	800F-Q01	22.5mm PB No Latch, Spring-Clamp Contact Block, 1 N.C. (Red Spring)	Allen Bradley
QTY	ITEM NO.	PART NUMBER	DESCRIPTION	MANUFACTURER



SEE DETAIL "B"

**Figure 27: Way Side Console Assembly Drawing**

## DETAIL "B"

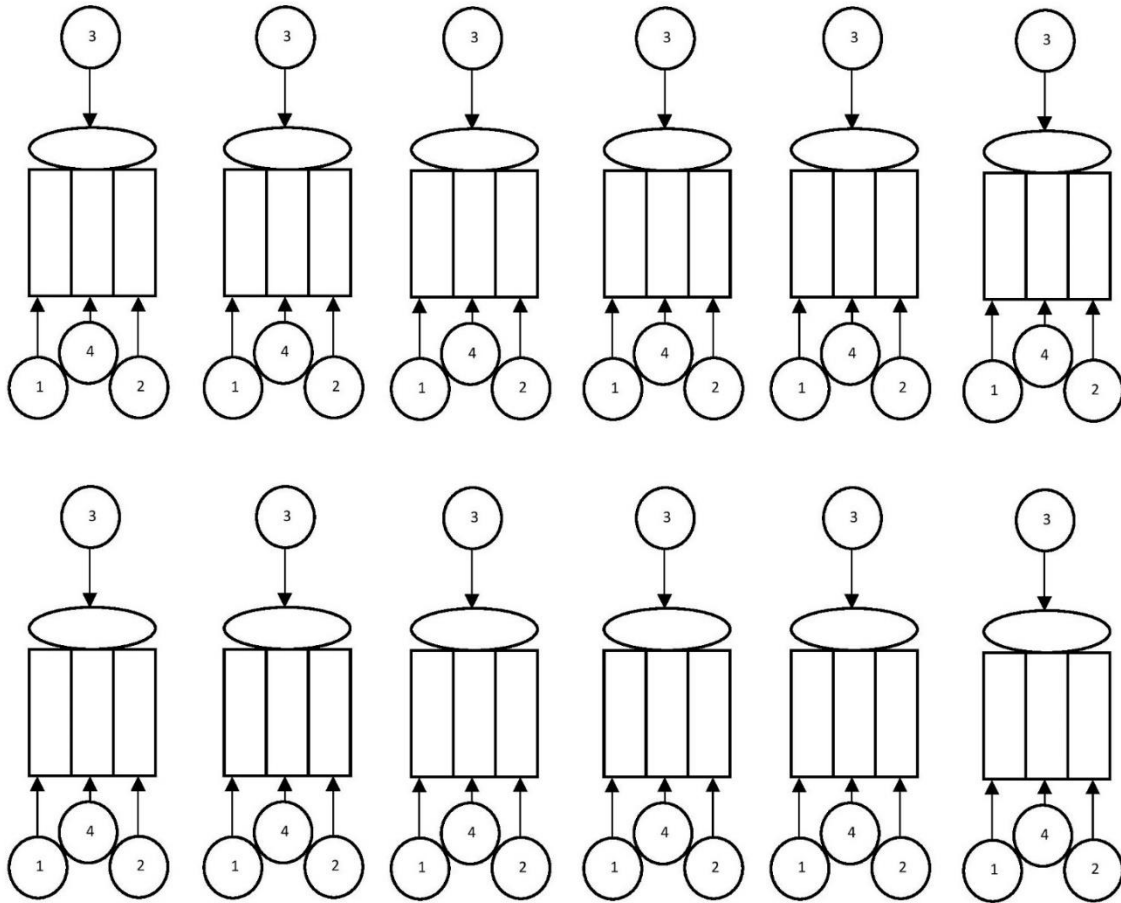
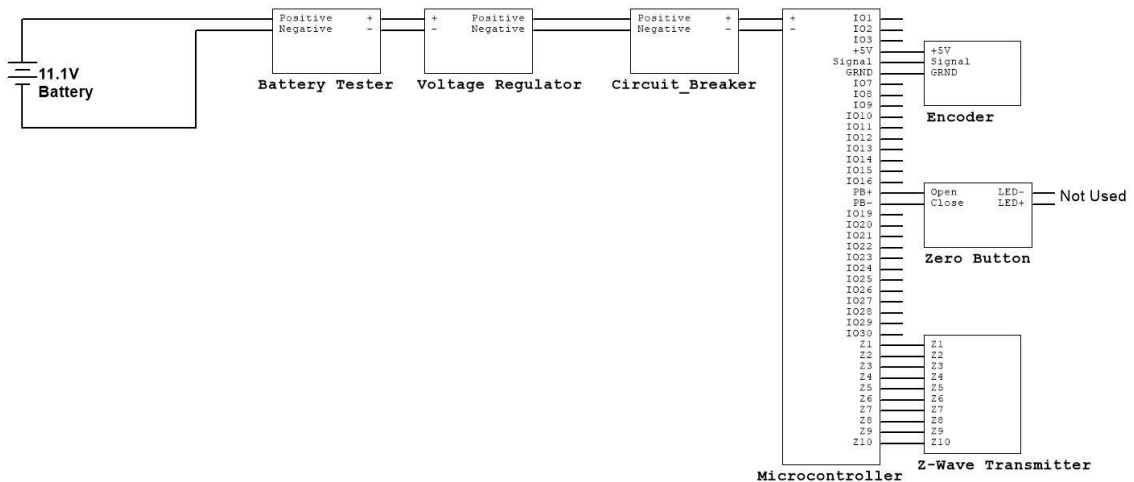

Figure 28: Way Side ████ Control Panel Detail "B" Assembly Drawing

### 6.1.4 On-Board Housing Assembly Details

The on-board components will be powered by a 22000mAh battery at 11.1V. The battery will be constantly tested by a battery tester to check on the voltage difference between the wires to show the battery life in terms of amp-hours or watt-hours. The connection between the battery and battery tester will be a XT60 connector. Then the power is distributed to a voltage regulator to step down the voltage to 5V as shown in Figure 29. The power goes through a circuit breaker as an added layer of security for the other on-board components. The 5V sent through the circuit breaker will go to a micro-USB connection which will attach to the microcontroller which will give power to the Z-Wave module and the encoder.



**Figure 29: On-Board Schematic**

A shafted absolute encoder will attach to the test objects shaft by an encoder coupling. The shaft of the encoder will be 1/4" and the coupling chosen will be for 1/4" to 1/4" mounting. The encoder will take read the angular position and send out the data in analog form to the on-board microcontroller. The microcontroller has a set of pins that are GPIO's, General Purpose Input/Output, and take in and send out values as either high or low values. These high and low values are determined by the input voltage. One GPIO pin on the on-board MCU will be used for the data from the encoder. The MCU will then use an algorithm to convert the encoder data in to Boolean values for the PLC. Afterwards, the MCU will use a secondary algorithm to ensure that the converted data represents the original data correctly. Then these converted values will be transferred to the Z-Wave module on the on-board MCU and sent way-side wirelessly.

### 6.1.5 Way-Side Housing Assembly

The way-side MCU has an attached Z-Wave module that will recognize the wireless signal being transmitted by the on-board Z-Wave module and receives the signal after confirming the source and strength of the signal. The module will then reverse the encapsulation process that the transmitter used to access the data and transfer it to the way-side microcontroller. The MCU will then take the transferred data and send through an output pin to the PLC as shown in Figure 30.



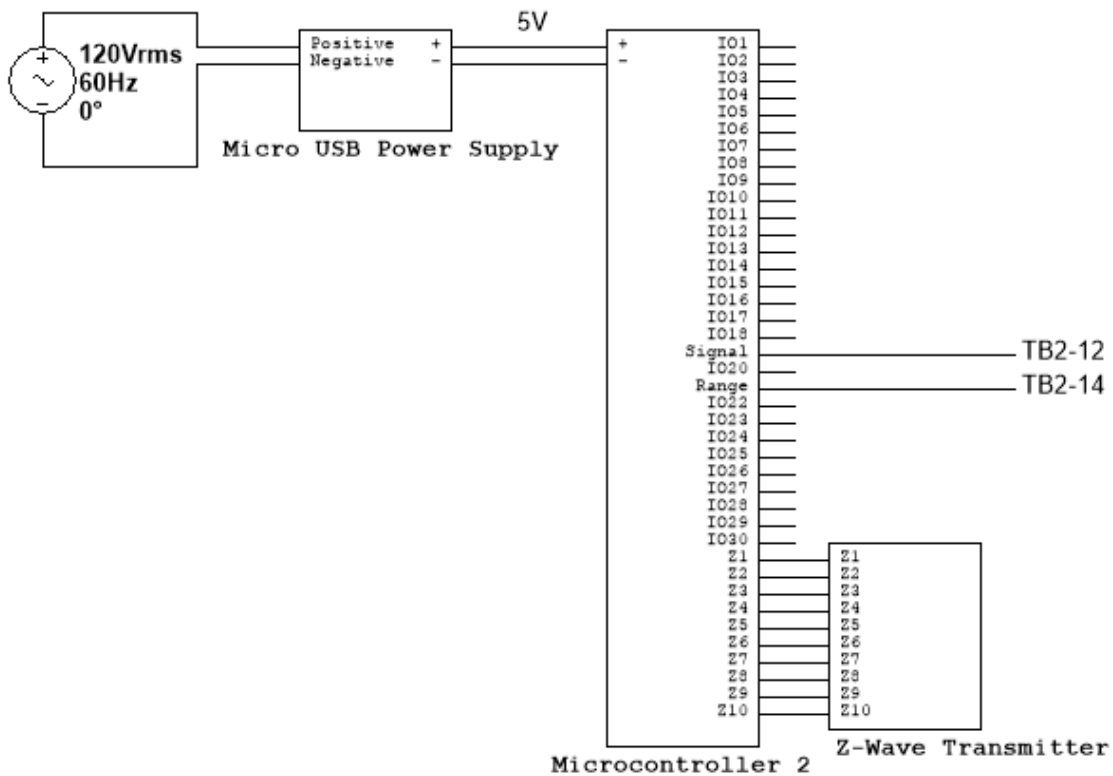

**Figure 30: Track Side Box Schematic**

The output truth table for the way-side receiving module and microcontroller is illustrated in Table 15: Output Truth Table for way-side receiver. The X in the truth table means the MCU will bypass this data and will output low for the signal output.

Signal	Received Data	Signal Output Pin	Range Output Pin
Received	TRUE	HIGH	HIGH
Received	FALSE	HIGH	LOW
Not Received	TRUE	LOW	X
Not Received	FALSE	LOW	X

**Table 15: Output Truth Table for way-side receiver**

The PLC will have five inputs as shown in Figure 31. The two digital signals from the way-side MCU, the stuck button, the polling button and the [REDACTED] key button. The digital signal will determine if the test object is in range or out of range and if a signal was sent or not. The stuck button will determine if the test object is stuck or not stuck. The polling button will simulate different polling points as if the test object was moving around a track. The [REDACTED] key button will simulate a key being inserted into a turn lock which will reset the [REDACTED] stop request signal if

the abnormality in the operation has been corrected. The PLC will interpret the data and follow the truth in Table 16.

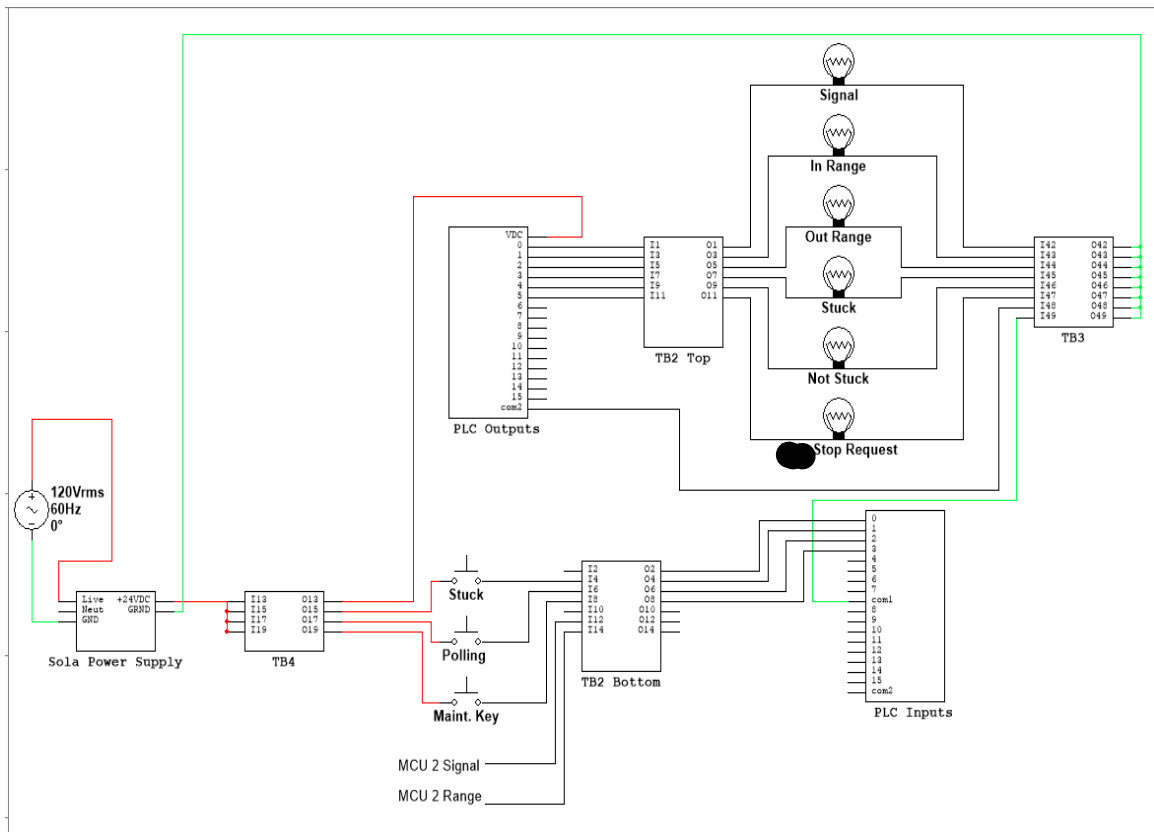

**Figure 31: Way Side I/O Schematic**

The PLC power supply will receive its power directly from the wall as illustrated in Figure 32. The input buttons going into the PLC will be powered from a separate power supply as shown in Figure 31. The same power supply will also power the PLC output module which provides power to the output lights.

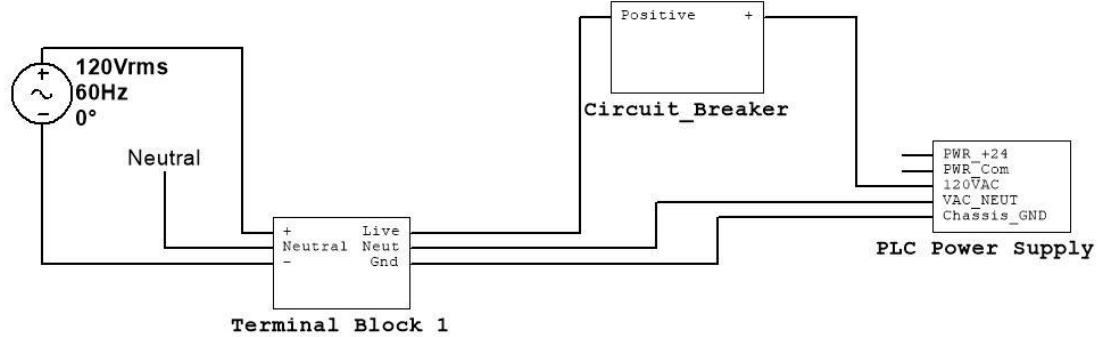

**Figure 32: PLC Power Supply Schematic**

## 6.2 Software Fabrication

The software fabrication process for designing the prototype are the steps used to apply the code to the different components. The project has multiple components that need to have software applied for them to operate nominally. The components are the two microcontrollers, the Z-Wave modules, and the PLC. This section will cover the application of the software to the on-board and way-side assemblies.

### 6.2.1 On-Board Housing Assembly

The on-board housing will have a microcontroller and an attached Z-Wave module that need to have software either designed or loaded to them. The microcontroller needs to be able to take in data from the encoder, zero the data, and communicate with the Z-Wave module. The microcontroller will have pre-loaded software that will allow it to read and interpret the data fed in to the pins on the board. There is also software that is provided by the Z-Wave module that allows the microcontroller to be able to share data with the device. The software that needs to be fabricated is how the microcontroller determines what to do when the push-button is pressed, what data is in range or out of range, and jumps in data which is discussed in section 6.3.1. The on-board Z-Wave module will need to be able to communicate with the microcontroller, encapsulate the data, communicate to with the way-side Z-Wave module, and send the data to the way-side Z-Wave module. All of the software needed by the Z-Wave module to have the ability to these actions are pre-loaded to the device.

### 6.2.2 Way-Side Housing Assembly

The way-side housing will have a microcontroller, a Z-Wave module, and a PLC that need to have software designed or loaded to them. The microcontroller needs to be able to communicate and take in data from the Z-Wave module on it and send the respective data to the PLC. The microcontroller will have pre-loaded software that allows it to communicate with the Z-Wave module. The

microcontroller just needs to be coded to send the correct data to the PLC which the code will be described in section 6.3.1. The Z-Wave module will have all of the appropriate software it needs loaded to it to be able to complete its assigned tasks. The PLC will have all of the appropriate software it needs loaded to it to be able to determine what it needs to do with the inputs given.

## 6.3 Coding

There will be four devices that require software coding in this design. The two Raspberry Pi microcontrollers. One is located on-board the test object and the other is located on the way side. The other two devices are the PCB and the PLC. The PCB will only be used on the test bench while the PLC will be located on the way side.

### 6.3.1 Microcontroller Coding

The coding for the microcontroller will be spilt up by what the on-board MCU will accomplish and what the way-side MCU will accomplish. To start, the on-board MCU is the device that will be determining if data given by the encoder is in range or out of range. This will be done by first by pressing a button which will zero the data being given to it by the encoder. The zeroing is started by storing the incoming encoder data in to three different variables that are the initial encoder data, the previous encoder data, and the current encoder data. Then the incoming encoder data is subtracted by the initial encoder data which will provide the value that goes in to current encoder data.

The next part of the process to be coded is the algorithms to determine the in range and out of range values. The first algorithm will be a set of if-else statements that will determine if the current encoder data is either in-range, out of range, or has jumped a significant amount. The MCU will start off by looking for a jump in data by comparing the current encoder data to the previous encoder data value. If a jump in data is found, the current encoder data will be set to 2 and sent to the value comparison code. If there is no jump the MCU will proceed to the next statement. The MCU will transfer the current encoder data to the previous encoder data. If the current encoder value is in-range, the current encoder data will be set to true. If not, the current encoder value will be set to false. The second algorithm will be case statements that follow the same method as the first algorithm. The only difference between the second and first algorithm is that when the second detects a big jump it will set the current encoder data to 3 instead of 2. The values from these two algorithms will be compared to determine if there was a failure. No failure means that they are the same and one of the values will be sent to the Z-Wave module, encapsulated, and transmitted. A failure will increment a counter and while that counter is less than 3, the MCU will request new data from the encoder. As soon as the failure counter reaches 3, the MCU will make the Z-Wave module send a signal to the way-side microcontroller to cause a signal not received flag to set.

The way-side microcontroller has a simpler code that will require it to send respective data through the signal output pin and range output pin. The signal output pins value is determined by two things. The first being if the Z-Wave modules for both on-board and way-side are communicating with each other. The second being from the failsafe's stop receiving signal flag from the on-board microcontroller. The code for both the on-board and way-side Z-Wave modules are provided by the software that comes with them.

### 6.3.2 PLC Coding

The language used to code the PLC will be ladder logic, as most PLC use this language as a standard. The PLC will have 5 inputs. The wireless signal received, range signal, stuck button, polling button and the [REDACTED] key button. The first three inputs will be used to illuminate the PLC output lights according to the truth table in Table 16. The PLC output lights are in range, out range, stuck, not stuck, [REDACTED] stop request and signal. Each light will illuminate according to the truth table in Table 16.

Signal Received	In Range Signal	Out of Range Signal	Stuck Button	Not Stuck Button	Operation	In Range Light	Out Range Light	Stuck Light	Not Stuck Light	[REDACTED] Stop Request Light	Signal Light
Yes	Yes	No	No	Yes	Normal	Yes	No	No	Yes	No	Yes
No	X	X	X	X	Abnormal	No	No	No	No	Yes	Blink
Yes	Yes	No	Yes	No	Abnormal	Yes	No	Yes	No	Yes	Yes
Yes	No	Yes	No	Yes	Abnormal	No	Yes	No	Yes	Yes	Yes
Yes	No	Yes	Yes	No	Abnormal	No	Yes	Yes	No	Yes	Yes

**Table 16: PLC Truth Table**

The polling button is to simulate the test object moving around a track passing another sensor to gather the next batch of data. When the polling button is pressed, it will reset all the illuminated lights except the [REDACTED] stop request light. Then wait 10 seconds before it pulls the next batch of data. The [REDACTED] key button is to simulate a technician inserting a key into a turn lock. This feature was an added addition to the design for resetting purposes. The [REDACTED] stop request light will stay illuminated until the [REDACTED] key button is pressed **and** the condition causing the operation to be outside of normal is corrected. If the [REDACTED] key button is pressed without the abnormal condition being correct, the [REDACTED] stop request light will stay illuminated. The PLC program will have a fail-safe procedure built in that will confirm the information it received is accurate. If somehow the PLC gets conflicting information when it receives the signal, then the PLC will blink the light of the input that is giving incorrect information. For example, if the PLC received the test object was stuck and not stuck in the same data package, the stuck and not stuck lights would blink indicating where the misinformation came from. The [REDACTED] stop request light will illuminate to ensure that the [REDACTED] is not operating in an abnormal mode.

### 6.3.3 PCB Coding

The PCBs coding will be relatively simple compared to the PLC and microcontrollers. The PCB will be coded to recognize the input being set by the potentiometer, the output being given by the encoder, and provide both sets of data to display on the LCDs. The other coding that will be applied is for the EEPROM on the PCB to send the data given by the input and encoder to their respective LCD displays.

### 6.4 Prototype Maintenance

When the prototype has been tested, it will have to be continued to be maintained. The maintenance routines will change depending on the components used in this project. This prototype will have an assigned routine schedule to keep the system up to date and accurate for the needs identified for [REDACTED]. For long term use, there will be reset buttons put in place to recalibrate the encoder if needed. A major reason to keep up with the maintenance is to make sure the system works when it is time for use. If the project is done before 48 hours, keeping this routine will keep it in pristine condition for presentation purposes. In Table 17 is a check list of the maintenance routine needed for this system.

Maintenance Check	Frequency	Automatically or Manually
Battery	Daily	Manually
PLC	Weekly	Manually
Receiver	Weekly	Manually
Transmitter	Weekly	Manually
Encoder	Daily	Manually
Wiring	Weekly	Manually

*Table 17: Maintenance Routine*

### 7.0 Realistic Design Constraints

When it comes to designing a project, there is many challenges to overcome. There are many constraints to take in consideration like time and budget related. This may be used for mechanical systems that might include people's life depending on what it is in cooperated in, so [REDACTED] and durability also would have to be accounted for. In creating a project that will be given to the following audience it will have to be reasonable to reproduce. Last but not least, it is also good to consider the potential environmental, political and ethical constraints that could be addressed to the end product.

## **7.1 Time and Economic Constraints**

Time is always against us, so using timely wisely is a goal for this. Construction is one of the most time-consuming aspects of this project. For instance, when ordering a part for the project, the shipping time plays in a great factor. If a broken or incorrect part is received, then that will cause more time to be used up waiting for the correct or fixed parts to come in. To help mitigate this problem, while some parts arrive is to start testing the components while the other parts are being waited on. Some parts of the project can't be rushed, for examples, soldering on the components and putting on the electronics properly.

The microcontroller and PLC will both have to be programmed which will also take a good amount of time. Using test benches and simulations can help get a running program, but like all things may not work correctly when it comes to programing the components. The programming of this project shouldn't be too complicated, such as checking for an angle, then seeing if it is in range or out of range and displaying the correct output from the PLC. The aspect that might take a little more time is making sure that there is a good handshaking going on between the receiver and transmitter for the microcontrollers for fast and accurate reading.

For this project the cost is not expected to be a lot. When choosing the parts, we chose to be a US company so shipping cost would not be extensive. We will be using a microcontroller that is used by Raspberry pi. In making things less stressful and time consuming we have chosen to do a Z-Wave module that will be compatible with the Raspberry Pi microcontroller so can just clip on the microcontroller versus applying extra wire not needed.

## **7.2 Manufacturability and Sustainability Constraints**

The manufacture and sustainability constraints are what would be found in any other project used for mechanical systems from construction to be integrating in robotics. We needed to take in consideration of how durable this product would be and how long would this project last. As well as taking in consideration of the portability of this project. This is considering the material the system is made from, the weight and size of it, and the power that will be used.

### **7.2.1 Durability and Expected lifetime**

From the ██████ aspect durability is a major concern for this project. The aspect lifetime of this project about 10 years or more with the proper maintenance based on educated estimates. The housing on this system goes in to contributing to this longevity of the system.

### **7.2.1.1 Durability**

The system must be water resistant. The relative humidity in Orlando, FL can range, on average, between 45% to 95% in the summer with an average dew point between 65-75 in the summer (Florida Climate Center, 2018). This type of weather pattern allows for increased condensation concerns, the likelihood of fog as well as higher potential for rain chances.

The on-board encoder is an absolute magnetic shaft encoder. This means that all internal components of the encoder are sealed inside the casing, so moisture cannot access the internal parts. The only exposed portion of the encoder are the pins which will be connected to the microcontroller by clip connectors with heat shrink. All other on-board components will be inside a weatherproof case.

The case is an L-Com Weatherproof Windowed Enclosure which is NEMA rated type 4 and IP66 rated. NEMA type 4 rated is a rating that signifies the enclosure is protected from windblown dust, falling dirt, water and the formation of ice. IP66 rated specifies that the enclosure is dust tight, protected against heavy seas, and powerful jets of water. Inside the case will be two Dry & Dry 5-gram Silica packets and a Dry & Dry Humidity Indicator. The 5-gram packets are each rated to absorb humidity in a 600-cubic inch container, so putting two in the case helps with Florida's humidity. The indicator card changes from green to violet when the humidity inside the enclosure reaches 30% and when this happens the card and packets need to be swapped.

The only way-side components that could be exposed to extreme moisture conditions would be the receiving microcontroller. This component would also be encased in a weather proof case and its power supply operating humidity range is 20-85%. The PLC would be inside an enclosure somewhere on the way-side and the display lights would be on a panel [REDACTED] in a control room.

### **7.2.2 Portability**

Given that [REDACTED] did want this to be a concept to be mobile, it is essential that this system will be a reasonable size and weight. The aim is to have a system in a 12x 12 x 12-inch surface. The weight should be fair enough where it would not make a big difference in affecting the object movement.

#### **7.2.2.1 Light Weight/ Relatively Small**

The encoder is a miniature encoder that has a diameter of .48 inches therefore the weight will be negligible. The encoder coupling will be about 1 inch in length with 1/4" to 1/4" bores making the weight negligible. The battery has dimensions of 6.22 x 2.33 x 2.40 inches weighing at 2.8lbs. Attached to the battery will be a voltage divider that is 2.4 x 1.3x 0.5 in. and weights 0.04 lbs. The Raspberry Pi microcontroller is 3.37" x 2.22" x 0.74" and weighs 0.1 lbs. The attached RaZberry



Z-Wave Module is 0.78" x 1.57" x 0.20" and weighs 0.035 lbs. The Powerwerx Watt Meter is 3.3" x 1.7" x 1.0" and weighs 0.18 lbs. The Raspberry Pi Power Supply is 2.88" x 1.78" x 1.38" and weighs 0.33 lbs. The L-Com Weatherproof Windowed Enclosure has outside dimensions of 13.3" x 11.3" x 5.5" and inside dimensions 12" x 10" x 4.8" and weighs 6.3 lbs. The Dry&Dry Silica packets are 2" x 2.75" and weigh 0.011 lbs. each. The Dry&Dry Humidity Indicators are 1.5" x 4.5" each and their weight is negligible.

## **7.3 Health, Safety, and Environmental Constraints**

For this system use of audience it should be safe for all use if properly constructed. There are a few components that could be dangerous or harmful. The factors that must be considered in the design is anything electrical that can cause an electrical shock or fire.

### **7.3.1 Hazardous Analysis**

The hazardous analysis is a potential off all danger or warning applications that could happen in this project. The likelihood is an analysis of how often something can occur. The fault tree helps identify the cause and effect of components in the system. The FMEA will try to trouble shoot the situation by figure out the main cause of what could potentially happen. All three analyses are in the following sections below.

#### **7.3.1.1 Likelihood**

The likelihood is the probability of a consequence occurring from a failure or mishap and considering the defined mitigations. Table 18 is a summary of the mishaps and the risk associated to it. Starting from the left of the high risk that is in red to be unacceptable to the right that is negligible risk that is in the green for acceptance.

Risk Characterization	High	Moderate	Low	Very Low	Remote	Negligible
Significant Injury Major Structural Damage	Red	Red	Red	Orange	Yellow	Green
Medical Assistance Needed	Red	Red	Orange	Yellow	Green	Green
Significant Evac Assistance	Red	Red	Orange	Yellow	Green	Green
Minor Structural Damage	Red	Red	Orange	Yellow	Green	Green
Assisted Evac	Red	Orange	Yellow	Electrical Fire	Green	Green
Significant Unavailability	Red	Orange	Yellow	Electrical Fire  Electrical Shock – way side	Green	Green
Conducted Evac	Orange	Yellow	Green	Electrical Shock – On-board  Corrosion	Green	Green
Other Operation Impact	Orange	Yellow	Green	Electrical Shock – On-board  Corrosion	Green	Green
Minimal Effect	Yellow	Green	Green	Green	Green	Green

Unacceptable
Question
Marginal
Acceptable

Table 18: Likelihood Table for mitigation

### Hazards Likelihood Break-Down

Electrical Shock likelihood is considered very low.

Electrical Fire likelihood is considered very low.

Corrosion likelihood is very low.

### 7.3.1.2 Fault Tree Analysis

The fault tree analysis below in Figure 33 shows a cause and effect. If either one of the components used in the project do not work, there can be a list of different reasons why and that is what the fault tree is supposed to help find. In other words, the fault tree is like a manual for trouble shooting if something does not end up working.

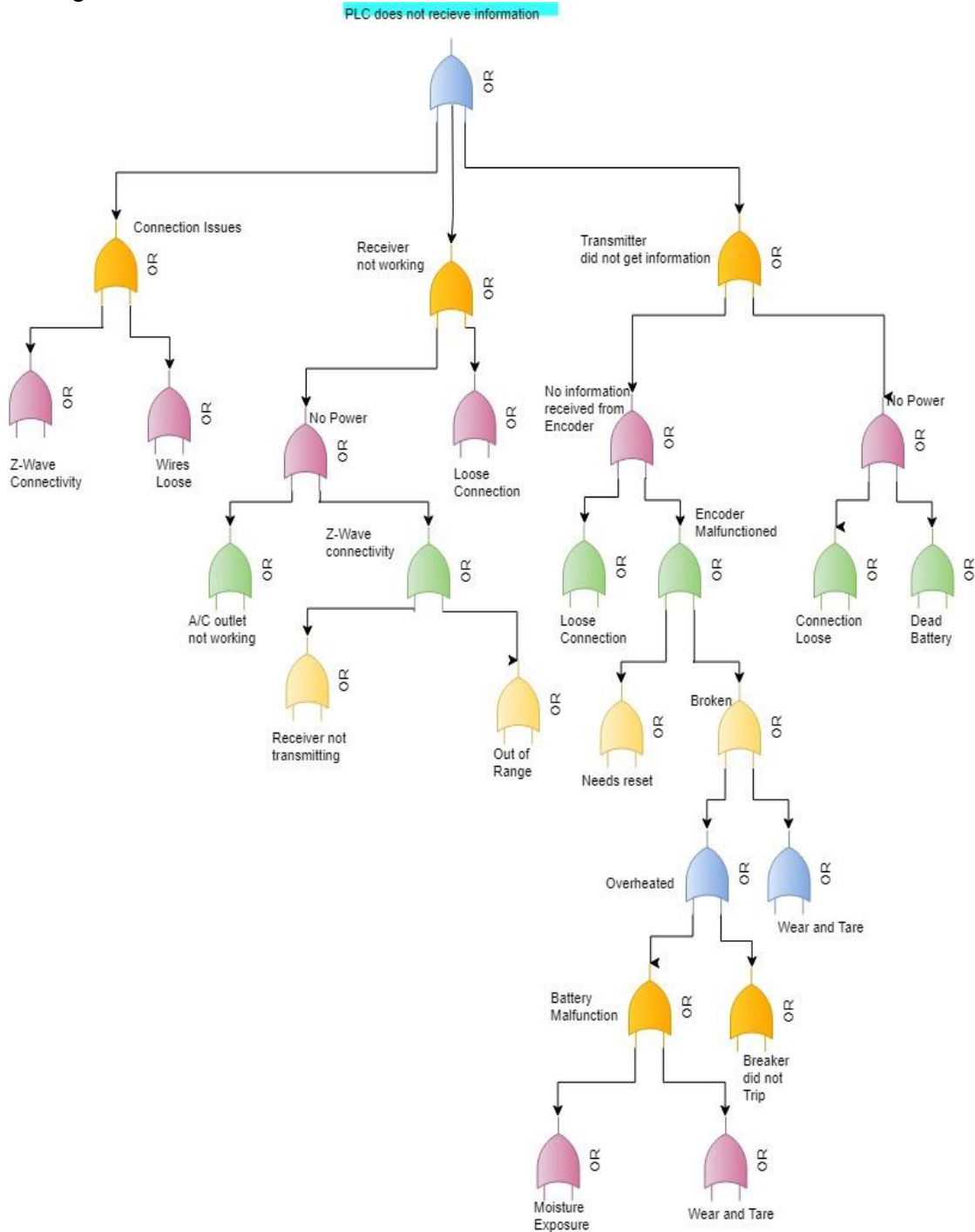

Figure 33: Fault Tree Analysis of Problems

### 7.3.1.3 FMEA's

Components fail all the time but when it fails there could be a domino effect that can happen. In Figure 34 shows each failure, and what that failure would effect on each of the other components. Starting by identifying the parts that are in the system. Then identifying how the parts could fail. Finally, determining the resultant effects of the failures relative to the undesired outcomes. For the Failure Modes and Effects Analysis is effective at making sure that every part of the system is considered and knowing the common failures, where the original failure can lead to other failures.

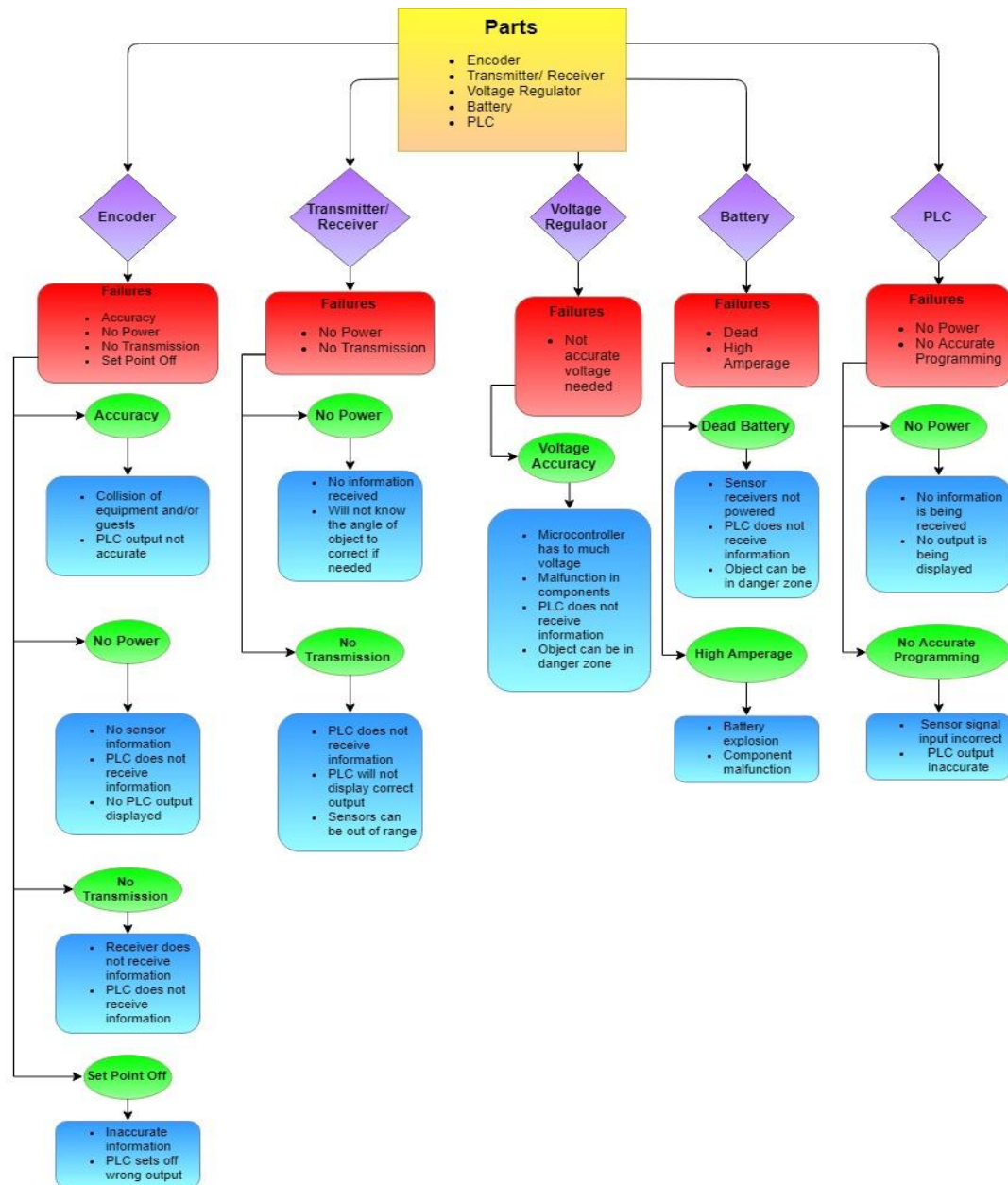

Figure 34: Failure Modes and Effects Analysis (FMEA)

### 7.3.1.4 Fail Safe

The encoder ensures the position is maintained when a power outage occurs, this ensures an accurate position is always maintained. The MCU will also store this maintained position in non-volatile memory storage which will ensure that the data coming in from the encoder is correct. Once the angular position enters the on-board microcontroller, the data will be converted and tested as follows Figure 35.

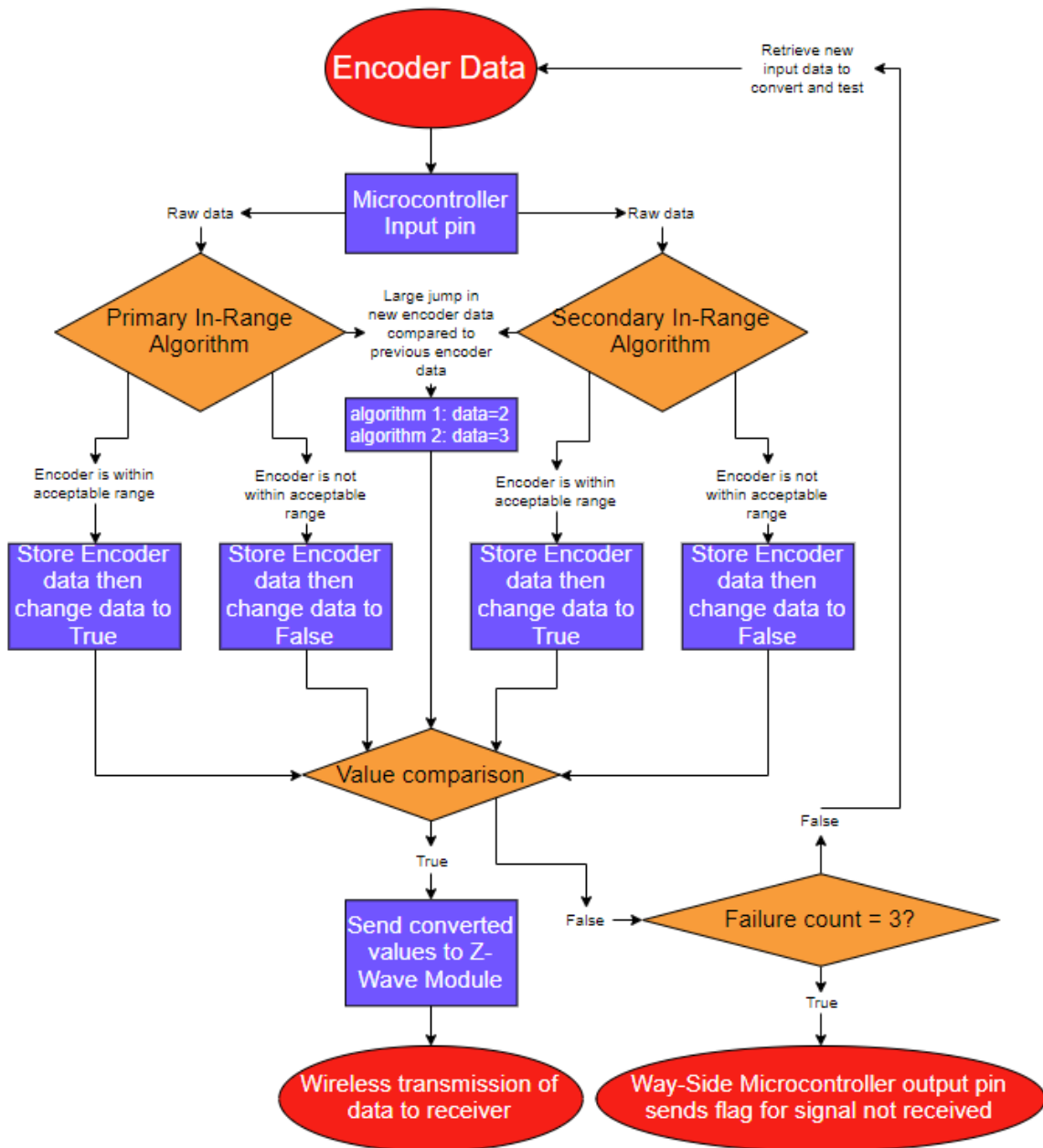

Figure 35: On-board failsafe code flow diagram

The first algorithm will be a set of if-else statements that will determine if the given value from the encoder is either an in-range angle or out of range angle. The MCU

will set a new value to true if the encoder value is in-range, or else the new value will be false because the original value was out of range. The second algorithm will be case statements based on the same encoder data the first algorithm uses. Case one will check if the encoder value is an in-range angle and if it is a new value is set to true. Case two will check if the encoder value is an out of range angle and if it is a new value is set to false. The values from these two algorithms using the same original data from the encoder will be compared. If they are the same, one of the values will be sent to the Z-Wave module, encapsulated, and transmitted. Table 19 shows the truth table of how the MCU uses both algorithms to determine whether or not to send the data.

Encoder Data	Primary Algorithm	Secondary Algorithm	Comparison
<b>In Range</b>	TRUE	TRUE	TRUE
<b>In Range</b>	TRUE	FALSE	FALSE
<b>Out of Range</b>	FALSE	TRUE	FALSE
<b>Out of Range</b>	FALSE	FALSE	TRUE

**Table 19: Truth table for algorithm comparison output**

The way-side microcontroller will receive the signal. When the inputs enter the PLC for interpretation, the PLC will ensure the information received is accurate shown in Figure 36. If there is misinformation, then the PLC will blink the light of the input that is giving incorrect information.

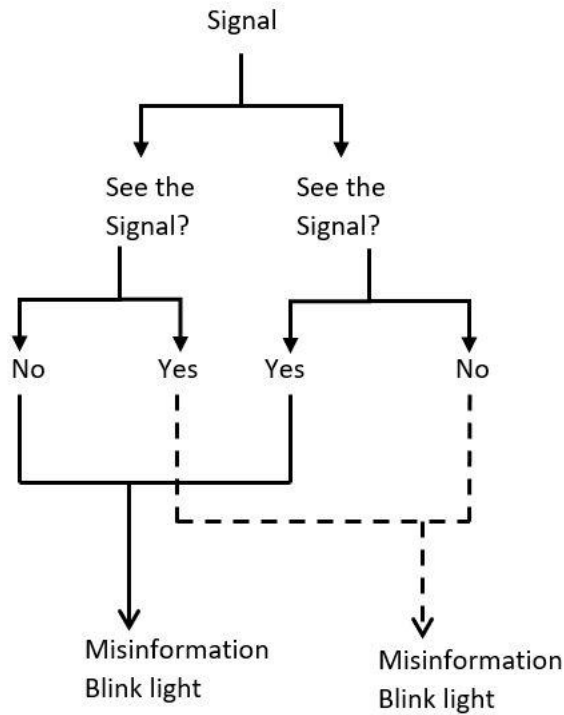

**Figure 36: PLC Fail Safe Tree**

## 7.3.2 Environmental Constraints

Our sponsor wanted this system to be robust. The robust aspects we considered was Florida weather conditions. In considering the weather changes the components chosen would be able to withstand these conditions. The other aspects that were taken into consideration was the temperature, wind, and light/dark environments.

### 7.3.2.1 Temperature

Florida has a record low of 19°F in 1985 and a record high of 101°F in 1998. On average, temperature range is between the low 50's (Fahrenheit) and the mid 90's (Fahrenheit) (Intellicast, 2018).

The encoder has an operating temperature of -40°F to 257°F which well exceeds any temperature extreme encountered in Florida.

The battery is a lithium polymer that can tolerate up to 140°F until thermal runaway occurs. Thermal runaway is when the battery heats up until the battery finally erupts in flame. Below 14°F, the shorter the run times which slows down the reaction within the battery, which could cause sudden failure.

The voltage regulator operating temperature is -40°F up to 185°F.

The PLC operating temperature is 32°F to 140°F which could cause a concern in low temperatures if stored outside, but the PLC will be located in an enclosure somewhere on way-side. This would eliminate any low temperature apprehensions.

The Raspberry Pi 2 model B and RaZberry Z-Wave module have the same operating temperature of -40°F to 158°F.

The Raspberry Pi Power Supply's operating temperatures are 32°F to 104°F.

The L-Com Weatherproof Windowed Enclosure, Dry & Dry Silica packets and humidity indicators have negligible temperature tolerances.

### 7.3.2.2 Wind

Florida is known for its hurricane potential, so wind gusts and sustained winds can be extremely high, but this is outside normal operating conditions. On average, the winds in Orlando, FL do not exceed 10 mph with gusts up to 30 mph (Florida Climate Center, 2018).

Even with gusts up to 30 mph, none of the components are susceptible to wind. The encoder would be mounted to the test object and all other onboard components would be encased. The way-side microcontroller would be encased as well. The PLC will be in an enclosure and the display lights will be on a panel inside.

### **7.3.2.3 Light/ Dark**

Florida averages between 10 hours and 14 hours of daylight each day depending on the time of year (Time and Date, 2018). [REDACTED] operating hours can easily extend from daylight hours into the night and [REDACTED] can shift from inside zones to outside zones and vice versa.

None of the components are light sensitive meaning each component can operate at high levels of light and complete absence of light.

## **7.4 Ethical, Social, and Political**

In any project it is important to weigh in any social, ethical, or political constraints. The last thing anyone wants in building a project is any upset people towards the design. For this project, no ethical constraints are really needed. There is no certain ethnic part that of this project that would make anyone angry or not be able to consider. One social constraint is that this project was created with a team based in US and the primary language would be English. This is not of great concern because any manual created or etc. can be translated to many other languages. For the political aspect there is nothing the team is aware of that would be a contribute to a political constraint on this project.

## **7.5 Sponsor Constraints**

The system can meet all the requirements listed by our sponsor [REDACTED]. Table 20 and Table 21 list each requirement / specification and how each component meets those requirements / specifications. These tables are meant to be a quick reference guide and are not all inclusive. For further details, see each requirement details listed throughout section 7.0 Realistic Design Constraints.



Requirement	Encoder	Voltage Regulator	Microcontroller 1	Battery	Battery Tester
Moisture	Completely encased except wiring, which is shielded	NEMA Case with silica packs	NEMA Case with silica packs	NEMA Case with silica packs	NEMA Case with silica packs
Temperature (in °F)	-40 to 257	-40 to 185	-40 to 158	14 to 140	no ratings
Windy	Not susceptible	Not susceptible	Not susceptible	Not susceptible	Not susceptible
Light / Dark	Not susceptible	Not susceptible	Not susceptible	Not susceptible	Not susceptible
Accurately Transmit/Receive					
Reliably Transmit/Receive			2 sets of algorithms to ensure giving proper data to transceiver		
Angular Position Accuracy	10-bit resolution so each position accounts for 0.351 degrees				
In Range Display (0-60°)			Determines if in range, sends information on to transceiver		
Out of Range Display (60° - 90°)			Determines if out of range, sends information on to transceiver		
Battery Level Display					Displays battery levels in volts, amps, watts, and amp-hrs or watt-hrs
Signal Received Display					
Stop Request Display					
Angular Position Display	See testing section				
Standard Voltage for Battery				11.1 V	
Battery life of 1 day				Calculated 30 hours of power	
Commercial Off the Shelf Parts	COTS	COTS	COTS	COTS	COTS
Supported for PLC I/O			Converts signal into digital		
Light Weight / Relatively Small	.48" diameter, negligible weight	2.4" x 1.3" x 0.5", 0.04lbs	3.37" x 2.22" x .074", 0.1lbs	6.22" x 2.33" x 2.40", 2.8lbs	3.3" x 1.7" x 1.0", 0.18lbs
Potential Use in Dynamic Situations	Analog encoder				
Vibration Tolerant	20G from 5Hz to 2kHz	Robustly designed	Robustly designed	Designed for drones and RC's therefore vibration tolerant	Robustly designed
Fail Safe	Absolute encoder ensures position in case of power outage		2 sets of algorithms to ensure getting same data before sending to transceiver, also has non volatile memory in case of power outage		

**Table 20: Requirements / Specifications Fulfillment Table for On-Board**

Requirement	Transceiver	Microcontroller 2	PLC
Moisture	NEMA Case with silica packs	NEMA Case with silica packs	Way-Side Enclosure
Temperature (in °F)	-40 to 158	-40 to 158	
Windy	Not susceptible	Not susceptible	
Light / Dark	Not susceptible	Not susceptible	
Accurately Transmit/Receive	+/- 27 parts per million frequency sent at bit rate of 40kbits/s		
Reliably Transmit/Receive	dependent on microcontroller		
Angular Position Accuracy			
In Range Display (0-60°)	receives info and sends to microcontroller 2	receives info and sends to PLC	Illuminates in range display light
Out of Range Display (60° - 90°)	receives info and sends to microcontroller 2	receives info and sends to PLC	Illuminates out range display light
Battery Level Display			
Signal Received Display		Sends signal through to PLC	Illuminates signal display light
Ride Stop Request Display			Program will determine if test object is in abnormal operation then illuminate RSR light
Angular Position Display			
Standard Voltage for Battery			
Battery life of 1 day			
Commercial Off the Shelf Parts	COTS	COTS	COTS
Supported for PLC I/O			Receives digital signal, other inputs are Allen Bradley components designed for PLC
Light Weight / Relatively Small	0.78" x 1.57" x 0.20", 0.035 lbs	3.37" x 2.22" x .074", 0.1lbs	Way-Side Enclosure
Potential Use in Dynamic Situations			
Vibration Tolerant	Robustly designed		
Fail Safe		Has non volatile memory in case of power outage	Program will run through 2 algorithms to ensure data is accurate before sending through to output displays

**Table 21: Requirements / Specifications Fulfillment Table for Way Side**

## 7.5.1 Accurately Transmit and Receive data

The accuracy of the on-board transmitting module is +/- 27 parts per million frequency error rate that is sent at a bit rate of 40 kbit/s. The ITU G.9959 recommendation, the standard used for Z-Wave devices, has a standard test frame and test conditions that ensures a minimum RF link which is determined by the way-side receiving module being capable of receiving the test frame at a minimum power level. The table the recommendation refers to is as follows in Table 22.

(International Telecommunications Union , 2015)

Term	Definition	Conditions
Standard test frame	PHY frame used for testing sensitivity	PHY frame with at least four bytes of random payload data.
Frame error rate (FER)	Average frame loss	Average measured over standard test frames.
Receiver sensitivity	Threshold input signal power that yields a specific FER	FER < 1% Power measured at antenna terminals. Interference not present.

**Table 22: Test frame and conditions to determine link quality**

The standard test frame is sent by the transmitting module to the receiving module during the startup of the network between to determine signal strength. The Frame error rate and receiver sensitivity is determined by taking the average of the data from multiple test frames. Once the signal strength conditions are met, the connection is established between the two modules. The way-side module will set an output of high if the signal is established. The module will send a low if the signal is either not established or the data conversion failed 3 times.

## 7.5.2 Reliably Transmit and Receive Data

The reliability of transmitting and receiving the data is dependent on the microcontrollers applying the algorithms that convert data correctly. The first algorithm is used by the on-board microcontroller to convert the encoder data in to Boolean values for the PLC to efficiently determine if the test object is in range or out of range. The second algorithm is used by the on-board MCU to determine if the first reliably converted the data in to the correct Boolean values by getting the same Boolean values with a different method. Once the data is reliably converted, it is sent to the on-board Z-Wave module and transmitted to the receiving way-side Z-Wave module. This Z-Wave wireless transmission has a reliable transmission range of 80 meters with a receiver sensitivity of -92 dBm. The way-side MCU will first determine if the receiving module is within range of the transmitting module. Once this is confirmed, the way-side MCU will take the data from the module attached to it and send the data to the PLC.

### 7.5.3 Angular Position Accuracy

The angular position accuracy must be within plus or minus 2°. The encoder has a 10-bit resolution. This means the entire 360° is divided into 1024 individual parts, so each position accounts for 0.351°. The encoder is an absolute encoder so each 0.351° is given a different identifier therefore misidentification of an angle cannot occur. An additional feature of the absolute encoder is it retains its angle in case of a power outage adding an extra layer of angle accuracy.

### 7.5.4 In Range Display

A display light to show if the angle is within the “In Range” of 0°- 60° in both directions on a 180° linear direction rotation as shown in Figure 37 below.

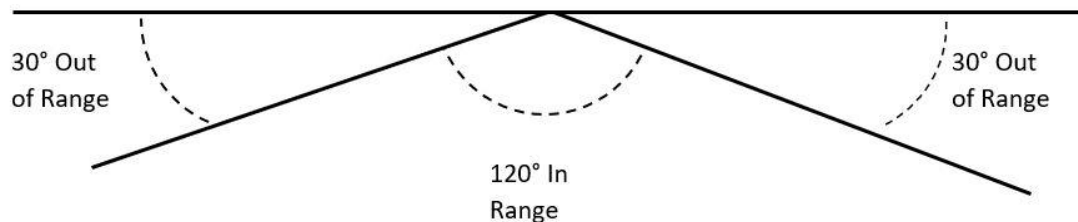

*Figure 37: In Range and Out of Range Angles*

As a design consideration, we are using parts and pieces accessible in the lab [REDACTED]. This allows for low cost and no lead time, but it also introduces unnecessary additional features not needed in the design. For example, we will be using a push button that has an illuminating light inside. The push button will not be utilized only the light portion. The in-range display light will be from some type of component that has illumination capabilities.

### 7.5.5 Out of Range Display

A display light to show if the angle is within the “Out of Range” of 61°- 90° in both directions on a 180° linear direction rotation as shown in Figure 1 above. As a design consideration, we are using parts and pieces accessible in the lab [REDACTED]. The out of range display light will be from some type of component that has illumination capabilities.

### 7.5.6 Battery Level Display

The Powerwerx Watt Meter will have its source attached to the voltage regulator and load attached to the Raspberry Pi MCU. This battery monitor will observe the capacity of the attached battery. The battery monitor has an LCD display that shows four values: voltage, amperage, watts, and the fourth value which can either be watt-hours or amp-hours. Amp-hours, or watt-hours, is the remaining battery

capacity and a marker as to if the battery needs to be charged. The in range and out of range values are displayed in Table 23.

Battery Monitor Values	In range Levels	Out of range Levels	Units
Amperage	0 - 2 ± .01	> 2	A
Voltage	4.5 - 5.5 ± .01	< 4.5 or > 5.5	V
Wattage	0 - 11 ± .1	> 11	W
Amp-hours	22000 - 5500 ± .001	5500 - 0	A-h

*Table 23: Battery monitor value reference table*

### 7.5.7 Signal Received Display

A display light to show if the PLC received the signal from the way-side receiver. This verifies that the wireless transmission is operating normally, and the data received is accurate. As a design consideration, we are using parts and pieces accessible in the lab [REDACTED]. The signal display light will be from some type of component that has illumination capabilities.

### 7.5.8 [REDACTED] Stop Request Display

A display light to show if the test object is in abnormal operation such as being stuck or in an out of range angle. As a design consideration, we are using parts and pieces accessible in the lab [REDACTED]. The signal display light will be from some type of component that has illumination capabilities.

### 7.5.9 Angular Position Display

A display showing the angular position the encoder is detecting and sending to the microcontroller. See testing section.

### 7.5.10 Standard Voltage for Battery

The battery chosen is a lithium polymer battery. This battery has a 22000mAh capacity with a 11.1V rating. Has a true 40C rating for discharging that gives us a maximum continuous load of 880A which will be more than sufficient in this design. The power wires are a 12awg Deans Ultra wire that will then be attached to a XT60 female connector to plug into the battery tester. In charging the battery is added a JST-XH balancing tap for easy use when using the Imax b6 balance charger. It is 100% water proof and comes with a lifetime warranty.

### 7.5.11 Commercial Off the Shelf Parts

All parts and components of the design are to be commercial off the shelf. This clarifies that there is to be no customized or altered components in the design. All components are commercial off the shelf parts.

## **7.5.12 Supported for PLC I/O**

The information sent wireless must be able to be interpreted by a PLC and the outputs are to be handled by the PLC. The inputs coming into the PLC input module are designed for proper handling by the PLC. All output display lights will be handled by the PLC output module.

## **7.5.13 Potential Use in Dynamic Situations/ Environments**

The design must be able to handle analog information allowing it to be placed in a real-world application. The encoder is designed to give an analog output angle. This information is sent to the microcontroller which translates the information into digital form. This allows for the encoder to read in real time with no down time for sampling.

## **7.5.14 Vibration Tolerant**

The components on the test object must be vibration tolerant. The battery is designed for drone and RC's, so the vibration tolerance will be well sufficient for this design. The voltage regulator, Raspberry Pi, RaZberry Z-Wave Module, Powerwerx Watt Meter, Raspberry Pi Power Supply, L-Com Weatherproof Windowed Enclosure, Dry&Dry Humidity Indicator, and Dry&Dry Silica packets are all robustly designed for vibration tolerance. The encoder is rated for 20G from 5Hz to 2kHz.

## **8.0 Project Assembly**

After the power supply for the On-board system was completely assembled and functioning properly, the next step was to get the Raspberry Pi with the ZWave.me RaZberry device functional and powered by the On-Board power supply. First, the MCU was installed with the necessary software to boot to its operating system that way the RaZberry could be properly activated. The RaZberry was initialized by downloading pre-built software from the manufacturer that set up a user interface to test the communication capabilities of the module. Once the On-board MCU was initially set up, the Way-Side MCU was initialized the same way. The next step was to confirm that the On-Board and Way-Side modules could communicate with each other before applying the customized software for our project. Following the communication confirmation, the Way-side was designated as the device to get values from the network of the Z-Wave modules and the On-Board was to set these values based on the input it received from the encoder. The next step in this process was to access the header files that controlled the command classes for the Z-Wave devices and create a program that could set and get values for the basic command class. The final steps in the process was to get the On-Board MCU to set the basic command class to True or False based on the conditions previously stated in this document and for the Way-Side to get those values from the basic command

class. Once these were both ready and the conditional programming was loaded to the On-Board MCU, the MCU was attached to the power supply using the microUSB connector it had attached. Lastly, the pin that was being utilized on the On-Board MCU was attached and ready to go to the test bench.

The test bench was our PCB that we created to help visualize the angle being set as an input and what the encoder was sending as an angle to the On-Board MCU as a range. The encoder is powered by the 5 volt and ground pins on the MCU and the data is fed in through a pin to the PCB test bench. The PCB itself was assembled by first creating a schematic that had all of the proper components attached and pins for power and inputs. A board was created from this schematic and then sent to a PCB manufacturer. The parts were then ordered from mouser and then soldered on to the PCB and tested to make sure that it could power up and receive the proper inputs. The PCB has a pin out that holds the encoder range that the On-Board MCU receives. This range is what sets the conditional statements to either True or False and subsequently sets the basic command class of the Z-Wave network to either on or off respectively. The PCB is also connected to power using a microUSB connector to a wall outlet and the PCB also provides power to the servo motor that sets the input angle and rotates the coupler attached to the encoder. Finally, with the PCB wired up and powered, the encoder powered and wired, and the enclosed MCU wired and powered this completed our On-Board assembly process.

The Way-Side assembly was done by first providing power to the MCU by attaching a microUSB power supply to the power strip powering the Way-Side components. Once the MCU had power, the pins that carried the signal and range outputs were wired up to an ATmega328 to step the 3.3 Volt outputs to the 5 Volt output minimum required by the step-up voltage regulators to get them to a proper 10-12 Volts to be recognized by the PLC. The step-up voltage regulators were receiving power on the input side from the ATmega328 outputs and respective grounds. The output side of the voltage regulator was grounded to the SOLA power supply and provided the necessary 10-12 Volt output for the PLC to recognize the inputs as off or on.

## **9.0 Project Prototype Testing**

In testing the components, a test plan will be developed. This will help ensure that the components and the devices will work in the intensions we are expecting from each datasheet. The testing will be extensive and will include each testing of the tasks. With these plans will help ensure the readings and the results are being accurate that is being outputted. First, the construction of the testing will start off with the characteristics that are going to be outlined in each data sheet to test the basics of each component. In knowing this will help secure the primary functions in the components.

## 9.1 Microcontroller Testing

The microcontroller will start being tested by hooking up a keyboard, mouse, ethernet cable, USB to microUSB power cable, and HDMI cable. This will allow the ability to program the Raspberry Pi 2 with an easy to navigate graphical user interface. The ethernet cable being hooked up will allow the microcontroller to acquire its necessary software to code it. Having the interface will allow the ability to see in real-time what is going on in the microcontroller. The testing will be done by inputting different values in to the code stated above in 6.3.1.

## 9.2 Encoder Testing

The test bench will have a PCB that has either two LCDs or one LCD with the ability to display on two separate lines. The input LCD will display the angle that we are inputting into the encoder. The output LCD will display the angle coming out of the encoder. This will test the encoders ability to accurately read and transmit the correct angle.

## 9.3 Test Environment

For testing purposes, the test object will be stationary. In actual application, the test object would be moving around a track or in some way have movement. This means we will be testing movement scenarios, such as polling points and the test object being stuck, in other ways. (see section 6.3.2 PLC coding for greater details).

## 9.4 Transmitter Test Procedures

The transmitter test procedures are set by the Z-Wave modules. The only thing that needs to be done manually is setting the NodeIDs of the modules and putting them on the same HomeID. Once this is done the modules will attempt to communicate with each other as long as they have power. This will be observed by having power provided to both microcontrollers while the Z-Wave module is attached and having one of the microcontrollers user interface open on a monitor.

## 9.5 Wireless Communication

The wireless communication will be tested immediately after the transmitter test procedures are complete. This will be done by initially sending data from one microcontroller to the other to light up an LED on a bread board. This will determine if the microcontrollers can communicate with each other through the Z-Wave modules attached to them. Once this is confirmed, the in range and out of range code will be applied and tested. The microcontroller that has the on-board code on it will be given an arbitrary value to test and the value that is determined will be sent to the way-side microcontroller to light up an LED if the value is in range and a different LED if it is out of range.



## **9.6 PLC Test Procedures**

The testing for the PLC program will test the truth table listed in Table 16. It will also test that the polling button is waiting 10 seconds before it pulls new data and that all lights, but the [REDACTED] stop request, are being reset when the polling button is pressed. We will test that when the abnormal condition is corrected, and the [REDACTED] key button is pressed, the [REDACTED] stop request light resets. We will also test that if the [REDACTED] key button is pressed without correcting the abnormal condition, the [REDACTED] stop request light stays illuminated. We will attempt to test, to the best of our ability, the PLC receiving misinformation and blinking the appropriate lights to signal where the misinformation originated from.

## **10.0 Administrative Content**

For this section is the constraints that was used for the outside content. This is the organization material and the general overviews of the dynamics. The administrative content is the outline of the lifecycle of the project with having the milestones and the budget.

### **10.1 Project Milestone**

Project schedule/milestones for both semesters. The small-scale design for UCF will follow in suit with the schedule that has been set for the entire project. Microsoft Project will be used to develop and maintain the AP Project master plan and schedule as shown in Figure 38, Figure 39, Figure 40, and Figure 41.

Project						
ID	Task Mode	Task Name	Duration	Start	Finish	
1	✓	<b>Planning Phase</b>	<b>17 days</b>	<b>Wed 1/17/18</b>	<b>Fri 2/2/18</b>	
2	✓	<b>Concept Development</b>	<b>1 day</b>	<b>Wed 1/17/18</b>	<b>Wed 1/17/18</b>	
3	✓	Define Problem	1 day	Wed 1/17/18	Wed 1/17/18	
4	✓	<b>Proposal Process</b>	<b>17 days</b>	<b>Wed 1/17/18</b>	<b>Fri 2/2/18</b>	
5	✓	Define scope of work	1 day	Wed 1/17/18	Wed 1/17/18	
6	✓	Develop project estimate	1 day	Sat 1/20/18	Sat 1/20/18	
7	✓	Develop project schedule	1 day	Sun 1/21/18	Sun 1/21/18	
8	✓	Define project functional requirements	1 day	Wed 1/24/18	Wed 1/24/18	
9	✓	Identify applicable codes & standards	1 day	Fri 1/26/18	Fri 1/26/18	
10	✓	Identify project risks	1 day	Tue 1/23/18	Tue 1/23/18	
11	✓	Identify project resources	1 day	Thu 1/18/18	Thu 1/18/18	
12	✓	Create preliminary proposal	1 day	Tue 1/23/18	Tue 1/23/18	
13	✓	Internal review of proposal	1 day	Sat 1/27/18	Sat 1/27/18	
14	✓	Send proposal to customer	1 day	Sat 1/27/18	Sat 1/27/18	
15	✓	Follow up with customer	7 days	Sat 1/27/18	Fri 2/2/18	
16	✓	<b>Customer Approval Process</b>	<b>3 days</b>	<b>Wed 1/31/18</b>	<b>Fri 2/2/18</b>	
17	✓	Develop project plan	3 days	Wed 1/31/18	Fri 2/2/18	
18	✓	Assign resources	3 days	Wed 1/31/18	Fri 2/2/18	
19	✓	Prepare task list	3 days	Wed 1/31/18	Fri 2/2/18	
20	✖	<b>Design Phase</b>	<b>82 days</b>	<b>Tue 1/30/18</b>	<b>Sat 4/21/18</b>	
21	✓	<b>Project Kickoff</b>	<b>1 day</b>	<b>Tue 1/30/18</b>	<b>Tue 1/30/18</b>	
22	✓	Hold kickoff meeting	1 day	Tue 1/30/18	Tue 1/30/18	
23	✓	Establish communication guidelines	1 day	Tue 1/30/18	Tue 1/30/18	
24	✓	Setup periodic team meetings	1 day	Tue 1/30/18	Tue 1/30/18	
25	✖	<b>Requirements Development</b>	<b>8 days</b>	<b>Mon 2/12/18</b>	<b>Mon 2/19/18</b>	
26	✓	Requirement documents	8 days	Mon 2/12/18	Mon 2/19/18	
27	✓	Review with customer	8 days	Mon 2/12/18	Mon 2/19/18	
28	✖	<b>Analysis &amp; Design 30%</b>	<b>22 days</b>	<b>Thu 2/1/18</b>	<b>Thu 2/22/18</b>	
29	✓	Review & finalize codes & standards	4 days	Mon 2/12/18	Thu 2/15/18	
30	✓	Develop software development plan	4 days	Fri 2/16/18	Mon 2/19/18	
31	✓	Generate concepts	12 days	Thu 2/1/18	Mon 2/12/18	
32	✓	Evaluate & select concept	19 days	Thu 2/1/18	Mon 2/19/18	
33	✓	Develop electronic & controls equipment production drawings	8 days	Thu 2/15/18	Thu 2/22/18	
34	✓	Develop interface control documents	8 days	Thu 2/15/18	Thu 2/22/18	
35	✖	<b>Design Review 30%</b>	<b>10 days</b>	<b>Mon 2/19/18</b>	<b>Wed 2/28/18</b>	
36	✓	Hold internal technical design review	5 days	Mon 2/19/18	Fri 2/23/18	
37	✓	Incorporate changes from internal review	2 days	Sat 2/24/18	Sun 2/25/18	
38	✓	Prepare and send design review package	1 day	Sun 2/25/18	Sun 2/25/18	

Figure 38: Microsoft Project Schedule pg. 1

Project						
ID	Task Mode	Task Name	Duration	Start	Finish	
39	✓	Obtain concept buyoff	1 day	Wed 2/28/18	Wed 2/28/18	
40	✓	Hold customer design review	1 day	Wed 2/28/18	Wed 2/28/18	
41	✓	Update requirements documents as needed	1 day	Wed 2/28/18	Wed 2/28/18	
42	✓	<b>Analysis &amp; Design 60%</b>	<b>30 days</b>	<b>Thu 3/1/18</b>	<b>Fri 3/30/18</b>	
43	✓	Update software development plan	26 days	Thu 3/1/18	Mon 3/26/18	
44	✓	Develop production strategy	22 days	Fri 3/9/18	Fri 3/30/18	
45	✓	Develop electronic & controls equipment production drawings	5 days	Mon 3/12/18	Fri 3/16/18	
46	✓	Update interface control documents	18 days	Mon 3/12/18	Thu 3/29/18	
47	✓	Develop theory of operation	12 days	Thu 3/1/18	Mon 3/12/18	
48	✓	Develop hazard analysis	12 days	Thu 3/1/18	Mon 3/12/18	
49	✓	Develop detailed design document	5 days	Mon 3/12/18	Fri 3/16/18	
50	✓	<b>Design Review 60%</b>	<b>5 days</b>	<b>Thu 3/29/18</b>	<b>Mon 4/2/18</b>	
51	✓	Hold internal technical design review	1 day	Thu 3/29/18	Thu 3/29/18	
52	✓	Incorporate changes from internal review	1 day	Thu 3/29/18	Thu 3/29/18	
53	✓	Prepare and send design review package	1 day	Thu 3/29/18	Thu 3/29/18	
54	✓	Hold hazards analysis review	1 day	Thu 3/29/18	Thu 3/29/18	
55	✓	Hold customer design review	1 day	Mon 4/2/18	Mon 4/2/18	
56	✓	Update requirements documents as needed	1 day	Mon 4/2/18	Mon 4/2/18	
57	✓	<b>Analysis &amp; Design 70%</b>	<b>7 days</b>	<b>Mon 4/2/18</b>	<b>Sun 4/8/18</b>	
58	✓	Update production strategy	3 days	Mon 4/2/18	Wed 4/4/18	
59	✓	Update electronic & controls equipmen	7 days	Mon 4/2/18	Sun 4/8/18	
60	✓	Update interface control documents	7 days	Mon 4/2/18	Sun 4/8/18	
61	✓	Update theory of operation	4 days	Mon 4/2/18	Thu 4/5/18	
62	✓	Develop preliminary installation strategy	4 days	Mon 4/2/18	Thu 4/5/18	
63	✓	Update hazard analysis	5 days	Mon 4/2/18	Fri 4/6/18	
64	✓	Update detailed design document	5 days	Mon 4/2/18	Fri 4/6/18	
65	✓	<b>Design Review 70%</b>	<b>3 days</b>	<b>Mon 4/9/18</b>	<b>Wed 4/11/18</b>	
66	✓	Hold internal technical design review	1 day	Mon 4/9/18	Mon 4/9/18	
67	✓	Incorporate changes from internal review	1 day	Tue 4/10/18	Tue 4/10/18	
68	✓	Hold hazards analysis review	1 day	Mon 4/9/18	Mon 4/9/18	
69	✓	Hold customer design review	1 day	Wed 4/11/18	Wed 4/11/18	
70	✓	Update requirements documents as nee	1 day	Wed 4/11/18	Wed 4/11/18	
71	✓	<b>Analysis &amp; Design 90%</b>	<b>5 days</b>	<b>Thu 4/12/18</b>	<b>Mon 4/16/18</b>	
72	✓	Update production strategy	2 days	Thu 4/12/18	Fri 4/13/18	
73	✓	Update electronic & controls equipment production drawings	5 days	Thu 4/12/18	Mon 4/16/18	

Figure 39: Microsoft Project Schedule pg. 2

Project						
ID	Task Mode	Task Name	Duration	Start	Finish	
74	✓	Update interface control documents	5 days	Thu 4/12/18	Mon 4/16/18	
75	✓	Update hazard analysis	5 days	Thu 4/12/18	Mon 4/16/18	
76	✓	Update detailed design document	5 days	Thu 4/12/18	Mon 4/16/18	
77	✓	Talk about a test plan	5 days	Thu 4/12/18	Mon 4/16/18	
78	➡	<b>Design Review 90%</b>	<b>6 days</b>	<b>Mon 4/16/18</b>	<b>Sat 4/21/18</b>	
79	✓	Hold internal technical design review	1 day	Mon 4/16/18	Mon 4/16/18	
80	✓	Incorporate changes from internal review	1 day	Mon 4/16/18	Mon 4/16/18	
81	✓	Prepare and send design review package	1 day	Mon 4/16/18	Mon 4/16/18	
82	✓	Hold hazards analysis review	1 day	Mon 4/16/18	Mon 4/16/18	
83	✓	Hold customer design review	1 day	Fri 4/20/18	Fri 4/20/18	
84	✓	Update requirements documents as needed	1 day	Sat 4/21/18	Sat 4/21/18	
85	📅	<b>Design Release</b>	<b>1 day</b>	<b>Sat 4/21/18</b>	<b>Sat 4/21/18</b>	
86	✓	Release production drawings	1 day	Sat 4/21/18	Sat 4/21/18	
87	✓	Monitor scope, budget, schedule & requirements	1 day	Sat 4/21/18	Sat 4/21/18	
88	✓	Update project schedule & resource loading	1 day	Sat 4/21/18	Sat 4/21/18	
89	✓	Prepare project update	1 day	Sat 4/21/18	Sat 4/21/18	
90	➡	<b>Installation (Build) &amp; Testing Phase</b>	<b>102 days</b>	<b>Mon 3/26/18</b>	<b>Fri 7/6/18</b>	
91	➡	<b>Procurement &amp; Bid</b>	<b>54 days</b>	<b>Mon 3/26/18</b>	<b>Fri 5/18/18</b>	
92	✓	Develop bill of materials for purchased parts	21 days	Mon 3/26/18	Sun 4/15/18	
93	✓	Purchase parts	18 days	Fri 4/20/18	Mon 5/7/18	
94	✓	Procurement tracking	5 days	Tue 5/8/18	Sat 5/12/18	
95	✓	Inspect purchased parts	1 day	Mon 5/14/18	Mon 5/14/18	
96	✓	Implement production strategy	5 days	Mon 5/14/18	Fri 5/18/18	
97	➡	<b>Production</b>	<b>10 days</b>	<b>Mon 5/14/18</b>	<b>Wed 5/23/18</b>	
98	✓	Write software	10 days	Mon 5/14/18	Wed 5/23/18	
99	➡	<b>Installation</b>	<b>14 days</b>	<b>Mon 5/14/18</b>	<b>Sun 5/27/18</b>	
100	✓	Perform installation according to installation plan	3 days	Mon 5/14/18	Wed 5/16/18	
101	✓	Photo documentation	3 days	Mon 5/14/18	Wed 5/16/18	
102	✓	Finalize input to create/update maintenance requirements and job plans	2 days	Wed 5/16/18	Thu 5/17/18	
103	✓	Inspect installation	3 days	Thu 5/17/18	Sat 5/19/18	
104	✓	Finalize test plan	4 days	Sat 5/19/18	Tue 5/22/18	
105	✓	Develop preliminary training plan	2 days	Wed 5/23/18	Thu 5/24/18	

Figure 40: Microsoft Project Schedule pg. 3

Project						
ID	Task Mode	Task Name	Duration	Start	Finish	
106	🚀	Update and release drawings are required	3 days	Fri 5/25/18	Sun 5/27/18	
107	🚀	<b>Testing</b>	<b>32 days</b>	<b>Sat 5/26/18</b>	<b>Tue 6/26/18</b>	
108	🚀	Verify safety systems	3 days	Sat 5/26/18	Mon 5/28/18	
109	🚀	Implement test plan	4 days	Mon 5/28/18	Thu 5/31/18	
110	🚀	Perform I/O checkout	4 days	Fri 6/1/18	Mon 6/4/18	
111	🚀	Perform system functional tests	5 days	Tue 6/5/18	Sat 6/9/18	
112	🚀	Perform software tests	5 days	Sun 6/10/18	Thu 6/14/18	
113	🚀	Perform & complete ATP	7 days	Fri 6/15/18	Thu 6/21/18	
114	🚀	Complete punch-list items	3 days	Fri 6/22/18	Sun 6/24/18	
115	🚀	Release snapshot of software	1 day	Mon 6/25/18	Mon 6/25/18	
116	🚀	Upload redlined drawings	1 day	Tue 6/26/18	Tue 6/26/18	
117	🚀	<b>Turnover</b>	<b>9 days</b>	<b>Wed 6/27/18</b>	<b>Thu 7/5/18</b>	
118	🚀	Gather documents for turnover	2 days	Wed 6/27/18	Thu 6/28/18	
119	🚀	Update hazard analysis	3 days	Fri 6/29/18	Sun 7/1/18	
120	🚀	Conduct final turnover review	1 day	Mon 7/2/18	Mon 7/2/18	
121	🚀	Turnover to end user	1 day	Mon 7/2/18	Mon 7/2/18	
122	🚀	Update project schedule & resource loading	2 days	Tue 7/3/18	Wed 7/4/18	
123	🚀	Monitor scope, budget, schedule & requirements	1 day	Thu 7/5/18	Thu 7/5/18	
124	🚀	Implementation Phase Gate Review	0 days	Fri 7/6/18	Fri 7/6/18	
125	🚀	<b>Closeout Phase Task List</b>	<b>11 days</b>	<b>Mon 7/9/18</b>	<b>Fri 7/20/18</b>	
126	🚀	Post-██████ support	1 day	Mon 7/9/18	Mon 7/9/18	
127	🚀	<b>Finalize Documentation</b>	<b>10 days</b>	<b>Tue 7/10/18</b>	<b>Thu 7/19/18</b>	
128	🚀	Finalize drawings/documents	2 days	Tue 7/10/18	Wed 7/11/18	
129	🚀	Finalize hazard analysis	1 day	Thu 7/12/18	Thu 7/12/18	
130	🚀	Release finalized software	1 day	Fri 7/13/18	Fri 7/13/18	
131	🚀	Release finalized ATP & ATR	1 day	Mon 7/16/18	Mon 7/16/18	
132	🚀	Closeout lesson learned	3 days	Tue 7/17/18	Thu 7/19/18	
133	🚀	Closeout Phase Gate Review	0 days	Fri 7/20/18	Fri 7/20/18	
134	🚀	<b>UCF Senior Design Presentation</b>	<b>14 days</b>	<b>Sat 7/21/18</b>	<b>Fri 8/3/18</b>	
135	🚀	Insert tasks for presentation	14 days	Sat 7/21/18	Fri 8/3/18	
136	🚀	Presentation	0 days	Fri 8/3/18	Fri 8/3/18	

**Figure 41: Microsoft Project Schedule pg. 4**

## 10.2 Budget and Finance

We anticipate the project budget rough order of magnitude to be \$10,000. This project will be funded by [REDACTED]. The UCF part of the project's budget will be roughly \$250 and may or may not be funded by [REDACTED]. In Table 24 is the breakdown of the cost for each component that will need to be bought. There are other components that are needed for this project, but [REDACTED] already had in the lab to use.

Part	Qty	Cost
5V Voltage Regulator	1	\$8.89
Battery	1	\$399.99
SKYRC iMAX B6AC	1	\$54.55
Connector – XT60	1	\$9.56
WattMeter-Bare	1	\$48.99
Encoder	1	\$55.50
Encoder connector	1	\$8.30
Encoder Coupling	1	\$50.00
Micro USB Power	2	\$9.00
Microcontroller	2	\$34.99
Zeroing push button	1	\$1.95
Z-Wave Module	2	\$49.99
<b>Total</b>		<b>\$725.71</b>

*Table 24: The cost of the parts needed*

## 10.3 Team Organization

In working with [REDACTED] to complete their requirements as well as the PCB part for UCF being organized and staying to the timeline will be a huge factor for this project. In being organized helped the team move smoothly throughout the design process for both UCF and [REDACTED]. In making sure that [REDACTED] is understanding the design there were 3 major meetings with [REDACTED]. The first was a 30% review which we present to [REDACTED] two designs for consideration. Another review was the 60% review in where all the items and wiring will be explained as well as any hazards that come with the concept. Finally, was the 90% review which will be the final critics that was needed from the 60% and got the approval to start ordering the parts for senior design two. As far as the UCF side goes, the milestone helped keep all documentations due dates and make sure that they were completed. Continue using this process helped lead this group become successful at the end of Senior Design II.

## 10.4 House of Quality

The house of quality defines the relationship between a customer wants and the producer's capabilities. In Table 25, the customer, [REDACTED], shows what they want on the left-hand side and across the top is what the engineering requirements are. On the bottom of the table shows the targets we will set for depending on customer's needs.

		Engineering Requirements							
		Intall time	Dimensions	Power Output	Compatibility	Sensor Accuracy	Sensor Range	Cost	
		-	-	-	+	+	+	-	
Marketing Requirements	Cost	-		↓	↓		↓↓↓	↓↓↓	↓↓↓
	Weather Conditions	-					↓	↓	
	Ease of use	+	↓			↑			
	PLC I/O	+				↑			
	Weight	+	↑	↑	↓				↓
	Reliable	+		↓	↓	↑	↑↑	↑↑	
	Fail Safe	+	↓						↓
	Accuaracy	+			↓		↑↑	↑↑	
	Dimensions	-	↑	↑↑					↑
	Vibration Tolerant	-		↓	↓		↑↑		↓
	Targets for Engineering Requirements		<One week	12x12 inches	< 150 watts	PLC	±2 degree(s)	45 mm	< 10,000
	Strong positive Correlation	↑↑							
	Positive Correlation	↑							
	Negative Correlation	↓							
	Strong Negative Correlation	↓↓							
	Positive polarity	+							
	Negative Polarity	-							

Table 25: House of Quality

# Appendences

## Appendix A – Copy Right Permission

### A.1 Powerwerx



Hi Jenna,

Yes, you have permission to cite information from our website and/or us manuals.

Thanks for asking!

Sincerely,  
Tom Mirabella  
Team Powerwerx

---

### A.2 Battery – MaxAmps

Jenna,

Thank you for choosing MaxAmps for your RC needs. I understand you would like to use our 22000mah 3s battery for a project and would like to use the details from our website in a paper you are writing. I don't see an issue with that at all.

If you have any questions I would be happy to help.

Josh Barker  
PR/Marketing  
[www.MaxAmps.com](http://www.MaxAmps.com)  
Toll free 888 654 4450  
Local 509 473 9883



## A.3 Raspberry Pi

Jenna

Thank you for your interest in Raspberry Pi.

Our learning resources and documentation are all Creative Commons licensed, we encourage people to translate and other wise adapt them. You'll just need to abide by the terms of the licence. (See <https://www.raspberrypi.org/creative-commons/>).

Regards

Nicola Early  
Administrator  
Raspberry Pi

A Creative Commons licence is used when an author wants to give people the right to share, use and build upon a work that they have created.

– [Wikipedia](#)

The licence we use is [CC BY-SA](#) (attribution and share-alike), which is the licence used by Wikipedia.



You are free:

- **to Share** – to copy, distribute and transmit the material, and
- **to Remix** – to adapt the material

Under the following conditions:

- **Attribution** – You must attribute the materials to the Raspberry Pi Foundation (but not in any way that suggests that they endorse you or your use of the materials), as well as including a link to the original resource. You must also indicate if changes were made.
- **Share Alike** – If you alter, transform, or build upon these materials, you must distribute the resulting materials under the same licence.

## A.4 Angle Position Sensor IC

### LEGAL NOTICE

Copyright 2017 Allegro MicroSystems, LLC ("Allegro"). All Rights Reserved.  
Permission is hereby given to copy any information contained herein, provided it is clear on the copy that the information came from Allegro.

# A.5 Information Reference - Spend Edge

Permission requested 4/20/18 – Awaiting approval

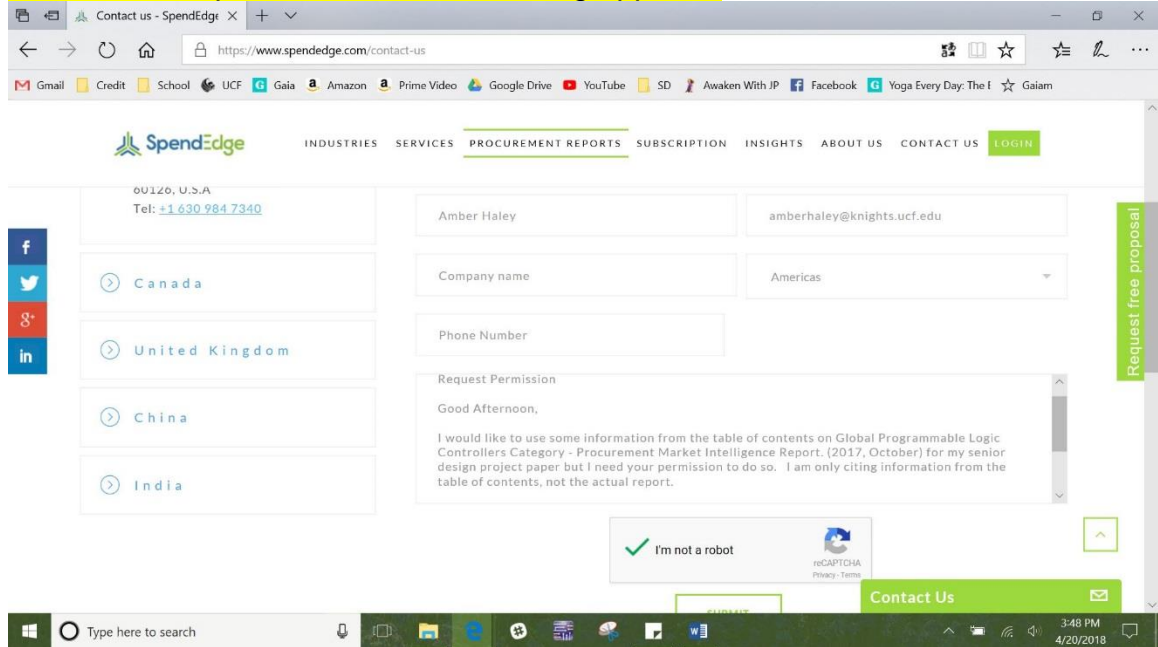

# A.6 Encoder

**From:** Heidi Smith <[Heidi.Smith@usdigital.com](mailto:Heidi.Smith@usdigital.com)>  
**Date:** April 23, 2018 at 11:39:49 AM EDT  
**To:** "[amberhaley@knights.ucf.edu](mailto:amberhaley@knights.ucf.edu)" <[amberhaley@knights.ucf.edu](mailto:amberhaley@knights.ucf.edu)>  
**Subject:** **RE: Permission Request**

Hello Amber,

There are no concerns with you using images and/or information from the USD website for your project paper.

We wish you the best of luck with your senior design project!

Thank you,

**Heidi Smith**

Customer Service Supervisor  
[heidi.smith@usdigital.com](mailto:heidi.smith@usdigital.com)



[usdigital.com](http://usdigital.com)  
1400 NE 136th Ave.  
Vancouver, WA 98684

Direct: [360.260.2468](tel:360.260.2468) EXT: 2133 (Pacific)  
Local: [360.260.2468](tel:360.260.2468)  
Sales: [800.736.0194](tel:800.736.0194)

## A.7 Encoder Coupling

**From:** Jameson Longanecker <[jamesonl@encoder.com](mailto:jamesonl@encoder.com)>  
**Date:** April 20, 2018 at 6:27:38 PM EDT  
**To:** "[amberhaley@Knights.ucf.edu](mailto:amberhaley@Knights.ucf.edu)" <[amberhaley@Knights.ucf.edu](mailto:amberhaley@Knights.ucf.edu)>  
**Cc:** Danielle Ward <[daniellew@encoder.com](mailto:daniellew@encoder.com)>  
**Subject:** FW: Permission Request

Hi Amber – Thanks for choosing one of our products to utilize!

Yes, you have permission. BUT, we're curious and would like to know what your project is. 😊 Can you share?

Regards,

**Jameson Longanecker**

Encoder Products Company | [www.encoder.com](http://www.encoder.com)

464276 Highway 95 South | Sagle, Idaho 83860

T: [800.366.5412](tel:800.366.5412) Ext. 4750 | F: 208.263.0541

## A.8 Z-Wave.Me RaZberry Z-Wave plus GPIO card

Permission requested 4/21/18 – Awaiting approval



**Benjamin Williamson** <[bjwilliamson06@gmail.com](mailto:bjwilliamson06@gmail.com)>

to info

To whom it may concern,

My group and I will be using your RaZberry Z-Wave Plus GPIO card for our Senior Design Project for the University of Central Florida. We would appreciate it if we could use various pictures and data sheets of yours in the documentation for our project. Do we have you permission to do so?

Thank you for your time and consideration.

Sincerely,  
Benjamin Williamson

---

## A.9 16 mm illuminated push button – blue momentary



Benjamin Williamson <bjwilliamson06@gmail.com>

to support ▾

To whom it may concern,

My group and I will be using the 16 mm illuminated push button - blue momentary for our Senior Design Project for the University of Central Florida. We would appreciate it if we could use various pictures and data sheets of yours in the documentation for our project. Do we have your permission to do so?

Thank you for your time and consideration.

Sincerely,  
Benjamin Williamson



Adafruit Industries

to me ▾

all good, feel free to.

thanks,  
adafruit support

...

## A.10 Dry & Dry silica packets and humidity indicator cards

Permission requested 4/21/18 – Awaiting approval



Benjamin Williamson <bjwilliamson06@gmail.com>

to info ▾

To whom it may concern,

My group and I will be using your 5 gram silica gel desiccant and premium cobalt free humidity indicator cards for our Senior Design Project for the University of Central Florida. We would appreciate it if we could use various pictures and data sheets of yours in the documentation for our project. Do we have your permission to do so?

Thank you for your time and consideration.

Sincerely,  
Benjamin Williamson

## A.11 12x10x5 Inch Weatherproof Windowed NEMA Enclosure

Permission requested 4/21/18 – Awaiting approval



Benjamin Williamson <bjwilliamson06@gmail.com>

to customerservice ▾

To whom it may concern,

My group and I will be using your 12x10x5 Inch Weatherproof Windowed NEMA Enclosure only for our Senior Design Project for the University of Central Florida. We would appreciate it if we could use various pictures and data sheets of yours in the documentation for our project. Do we have your permission to do so?

Thank you for your time and consideration.

Sincerely,  
Benjamin Williamson

## Appendix B Data Sheets

### B.1 Encoder



# MA3

Miniature Absolute Magnetic Shaft Encoder  
Page 2 of 8



#### Environmental

Parameter	Value	Units
Operating Temperature	-40 to +125	C
Vibration (5Hz to 2kHz)	20	G
Electrostatic Discharge, Human Body Model MIL-STD-883E, Method 3015.7	± 2	kV



#### Mechanical

Specification	Sleeve Bushing	Ball Bearing
Moment of Inertia	$4.1 \times 10^{-6}$ oz-in-s <sup>2</sup>	$4.1 \times 10^{-6}$ oz-in-s <sup>2</sup>
Max. Shaft Speed (1)	100 RPM	15000 RPM
Max. Acceleration	10000 rad/sec <sup>2</sup>	250000 rad/sec <sup>2</sup>
Max. Shaft Torque	0.5 ± 0.2 in-oz (D - torque option) 0.3 in-oz (N- torque option)	0.05 in-oz
Max. Shaft Loading	2 lb. dynamic 20 lb. static	1 lb.
Bearing Life (2)	> 1,000,000 revolutions	$L_{10} = (18.3/F_r)^3$ Where $L_{10}$ = bearing life in millions of revs, and $F_r$ = radial shaft loading in pounds



1400 NE 136th Avenue  
Vancouver, Washington 98684, USA

info@usdigital.com  
www.usdigital.com

Local: 360.260.2468  
Toll-free: 800.736.0194

Rev. 171018085709

 **Description**

The MA3 is a miniature rotary absolute shaft encoder that reports the shaft position over 360 ° with no stops or gaps. The MA3 is available with an analog or a pulse width modulated (PWM) digital output.

Analog output provides an analog voltage that is proportional to the absolute shaft position. Analog output is only available in 10-bit resolution.

PWM output provides a pulse duty cycle that is proportional to the absolute shaft position. PWM output is available in 10-bit and 12-bit resolutions. While the accuracy is the same for both encoders, the 12-bit version provides higher resolution.

Three shaft torque versions are available: high torque (-D option), low torque (-N) and ball-bearing (-B). The high and low torque versions have a stainless steel shaft and brass bushing lubricated with grease to provide ideal torque for panel mount, human-interface applications. The ball-bearing version has a brass shaft and miniature precision ball bearings suitable for high speed and ultra low torque applications. The ball-bearing version is only available with a 1/8" shaft diameter.

Connecting to the MA3 is simple. The 3-pin high retention snap-in 1.25mm pitch polarized connector provides for +5V, output, and ground.



**Features**

- Miniature size (0.48" diameter)
- Non-contacting magnetic single chip sensing technology
- -40C to 125C operating temperature range
- 10-bit Analog output - 2.6 kHz sampling rate
- 10-bit PWM output - 1024 positions per revolution, 1 kHz
- 12-bit PWM output - 4096 positions per revolution, 250 Hz

 **Mechanical Drawing**

Parameter	Min.	Typ.	Max.	Units
Power Supply	4.5	5.0	5.5	Volts
Supply Current	-	16	20	mA
Power-up Time	-	-	50	mS

### Analog Output Operation

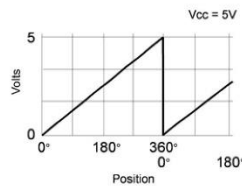

Analog output is only available in 10-bit resolution. The analog output voltage is ratiometric to the power supply voltage and will typically swing within 15 millivolts of the power supply rails with no output load. This non-linearity near the rails increases with increasing output loads. For this reason, the output load impedance should be  $\geq 4.7k\Omega$  and less than 100pF. The graphs below show the typical output levels for various output loads when powered by a 5V supply.

Parameter	Min.	Typ.	Max.	Units
Position Sampling Rate	2.35	2.61	2.87	kHz
Propagation Delay	-	-	384	?S
Analog Output Voltage Maximum (1)	-	4.987	-	Volts
Analog Output Voltage Minimum (1)	-	0.015	-	Volts
Output Short Circuit Sink Current (2)	-	32	50	mA
Output Short Circuit Source Current (2)	-	36	66	mA
Output Noise (2)	160	220	490	$\mu$ Vrms
Output Transition Noise (3)	-	0.03	-	Deg. RMS

- (1) With no output load. See graphs below.
- (2) Continuous short to +5V or ground will not damage the MA3.
- (3) Transition noise is the jitter in the transition between two adjacent position steps.

Specification	Sleeve Bushing	Ball Bearing
Weight	0.46 oz.	0.37 oz.
Max. Shaft Total Indicated Runout	0.0015 in.	0.0015 in.
Technical Bulletin TB1001 - Shaft and Bore Tolerances		Download

(1) The chip that decodes position uses sampled data. There will be fewer readings per revolution as the speed increases. The formula for number of readings per revolution is given by:

**10-bit PWM:**

$$n = 625200 / \text{rpm}$$

**12-bit PWM / Analog:**

$$n = 156600 / \text{rpm}$$

(2) only valid with negligible axial shaft loading

### Mounting

Parameter	Value	Units
Hole Diameter	0.375 +0.005 / -0.0	in.
Panel Thickness	0.125 max.	in.
Panel Nut Max. Torque	20.0	in-lbs

### Materials

Component	Material	Torque Option(s)
Shaft	Stainless	Sleeve Bushing (-D and -N options)
	Brass	Ball Bearing (-B option only)
Bushing	Brass	-

### Magnetic Field Crosstalk

The MA3 absolute encoder contains a small internal magnet, mounted on the end of the shaft that generates a weak magnetic field extending outside the housing of each encoder. If two MA3 units are to be installed closer than 1 inch apart (measured between the center of both shafts), a magnetic shield, such as a small steel plate should be installed in between to prevent one encoder from causing small changes in reported position through magnetic field cross-talk.

### Electrical



Parameter	Min.	Typ.	Max.	Units
Propagation				
10-bit	-	-	48	?S
12-bit	-	-	384	?S
Output Transition Noise, 12-bit version (1)		0.03		Deg. RMS
Output Transition Noise, 10-bit version (1)		0.12		Deg. RMS
Output High Voltage (V OH: @4mA Source) (2)	Vcc -0.5	-	-	V
Output Low Voltage (V OL: @4mA Sink) (2)	-	-	0.4	V

(1) Transition noise is the jitter in the transition between two adjacent position steps.  
 (2) Continuous short to +5V or ground will not damage the MA3.

**10-bit PWM:**

$$x = ((t_{on} * 1026) / (t_{on} + t_{off})) - 1$$

If  $x \leq 1022$ , then Position =  $x$

If  $x = 1024$ , then Position = 1023

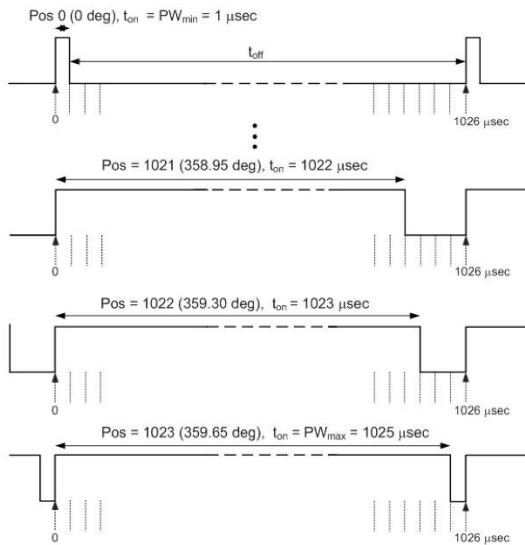

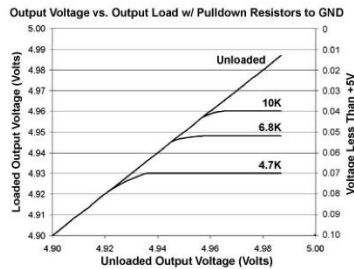
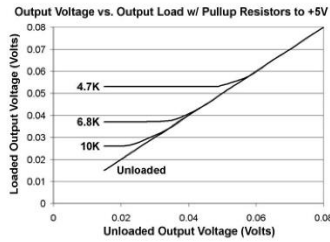

### PWM Output Operation

The magnetic sensor chip in the MA3 has an on-chip RC oscillator which is factory trimmed to 5% accuracy at room temperature (10% over full temperature range). This tolerance influences the sampling rate and pulse period of the PWM output. If only the PWM pulse width  $t_{on}$  and the nominal pulse period is used to measure the angle, the resulting value also has this timing tolerance. However, this tolerance can be cancelled by measuring both  $t_{on}$  and  $t_{off}$  and calculating the angle from the duty cycle.

Parameter	Min.	Typ.	Max.	Units
PWM Frequency (-40C to 125C)				
10-bit	0.877	0.975	1.072	kHz
12-bit	220	244	268	Hz
Minimum Pulse Width				
10-bit	0.95	1.00	1.05	µS
12-bit	0.95	1.00	1.05	µS
Maximum Pulse Width				
10-bit	974	1025	1076	µS
12-bit	3892	4097	4302	µS
Internal Sampling Rate				
10-bit	9.38	10.42	11.46	kHz
12-bit	2.35	2.61	2.87	kHz

## B.2 Raspberry Pi 2 Model B

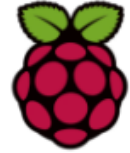

### Raspberry Pi2 Model B v1.2

**IMPORTANT: PLEASE UPDATE TO LATEST VERSION OF THE OPERATING SYSTEM**

Previous versions of Raspberry Pi 2 Model B use the BCM2836 SoC, which contains a quad-core ARM Cortex-A7 processor. The new release Raspberry Pi 2 Model B v1.2 board uses BCM2837, which contains a quad-core ARM Cortex-A53 processor. It is necessary to update to the latest (October 2016) version of the device firmware and Linux kernel to allow the board to boot up properly.

*To obtain updated software please go to:*

<https://www.raspberrypi.org/downloads>

*Installation guides are also available for the software as follows:*

*Raspbian Installation guide-*

<https://www.raspberrypi.org/documentation/installation/installing-images/README.md>

*NOOBS Installation guide -* <https://www.raspberrypi.org/documentation/installation/noobs.md>

#### **Product Overview**

The RASPBERRYPI-2-MODB-1GB is a second generation Raspberry Pi. Raspberry Pi2 model B board is a credit card sized single board computer that plugs into your TV and keyboard. This is a little PC which can be used for many of the things that desktop PC does.

The design is based on Broadcom BCM2837 system on chip with 900MHz ARM Cortex-A53 quad-core processor, Dual Core VideoCore IV Multimedia coprocessor and 1GB RAM.

This board is powered from 5V adapter with micro USB connectivity and runs on operating systems such as Raspbian, RaspBMC, Arch Linux, RISC OS, OpenELEC, Pidora and Microsoft Windows10.

- Broadcom BCM2837 SoC full HD multimedia applications processor
- 1GB SDRAM operates at 450MHz
- 40 pin extended GPIO
- 10/100 Ethernet RJ45 onboard network
- 4 USB 2.0 ports
- CSI camera port for connecting the Raspberry Pi camera
- DSI display port for connecting the Raspberry Pi touch screen display
- Featured with MicroSD slot
- Composite RCA and HDMI port
- Multi channel HD audio over HDMI, stereo from 3.5mm jack

#### **Product Information**

- **Silicon Manufacturer:** Broadcom
- **Core Architecture:** ARM
- **Core Sub-Architecture:** Cortex-A53
- **Silicon Core Number:** BCM2837
- **Kit Contents:** Raspberry Pi 2 Model B
- **Features:** Quad Core CPU, 1GB RAM, 900MHz Board Clock Speed, 40 GPIO Pins, 4 x USB Ports, 4 Pole Stereo Output, HDMI Port, 10/100 Ethernet, Micro SD Card Slot

# B.3 Micro USB Power Supply



## T5875DV Raspberry Pi Power Supply



### Features:

- Official Raspberry Pi Power Supply
- 1.5M Micro USB B Lead
- ErP Level 6 Efficiency Rating
- 50,000 Hour MTBF
- 1 Years Warranty



Output	
Output Voltage	+5.1Vdc
Minimum Load Current	0A
Nominal Load Current	2.5A
Nominal Output Power	13W
Output Regulation	+/-5%
Line Regulation	+/-2%
Ripple & Noise	120mVp-p Maximum
Rise Time	100mS Maximum at nominal input
Turn-on Delay	3 Seconds Maximum at nominal input
Protection	Short circuit, over current, over voltage
Efficiency	80.86%
Output Cable	1500mm Micro USB B 5 Pin

Input	
Input Voltage Range	90-264VAC
Input Frequency	47-63Hz
Input Current	0.5A Max
Inrush Current	No damage and IP fuse will not blow
AC Inlet	UK, Euro, Aus & US changeable heads

Other	
Dimensions	73.2 (L) * 45.1 (W) * 35.1 (H) mm
Weight	Approx 150g
Operating Temp.	0 °C to 40 °C
Storage Temp.	-20 °C to +60 °C
Operating Humidity	20 ~ 85 % RH. Non-Condensing
MTBF	50,000 Hours

### Diagrams

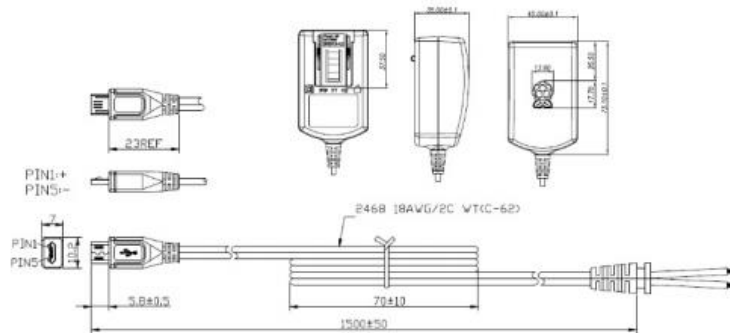

### STONTRONICS

Chancerygate Business Centre, Cradock Road, Reading, Berkshire, RG2 0AH.  
 Tel: +44 (0) 118 931 1199 • Fax: +44 (0) 118 931 1145 • Email: [info@stontronics.co.uk](mailto:info@stontronics.co.uk) • Web: [www.stontronics.co.uk](http://www.stontronics.co.uk)  
 Please Note: Image shown is representative of entire range. Individual PSU image &/or drawings or data sheets available on request.  
 Stontronics Ltd accepts no responsibility for typographical errors in the production of this leaflet. Product specifications are subject to change without notice.

## B.4 Z Wave Me RaZberry

### Technical Data

Z-Wave Transceiver	Sigma Designs ZM5202
Frequency	EU: 868.4 MHz (EN 300 220) RU: 869.0 MHz (GKRCh/EN 300 200) US: 908.4 MHz (FCC CFR47 P 15.249)
Wireless Range	Tested for >40 m in buildings, up to 100 m in free range
Dimensions	20 mm x 40 mm, weight is 16 gr.
Display	Red LED: Inclusion and Exclusion Mode Green LED: Send Data Indication
Interface to Host	TTL UART compatible to Raspberry PI GPIO pins
Compliance	RoHS, CE, FCC



## B.5 Powerwerx Watt Meter

### Specifications

- **Amps:** 45A continuous, 100A peak, 0.01 A resolution from 1 ~ 100
- **Voltage:** 0 ~ 60V, 0.01 V resolution (5 to 60V without optional auxiliary power connector)
- **Wire Type:** 12 gauge wire
- **Watts:** 0 ~ 7800W, 0.1 W resolution
- **Amp-hours:** 0 ~ 65Ah, 0.001 Ah resolution
- **Watt-hours:** 0 ~ 6554Wh, 0.1 Wh resolution
- **Display:** High-contrast blue backlit LCD display
- **Size:** 3.3 x 1.7 x 1.0" (85 x 42 x 24mm)
- **Weight:** 0.18 lbs. (82 g)
- **Warranty:** 1 Year Limited Warranty

## B.6 Battery Charger – SKYRC iMAX B6AC V2



### SPECIFICATION

- DC Input Voltage : 11-18V
- AC Input Voltage: 100-240V
- Display Type: 2x16 LCD
- Display Backlight: Blue
- Case Material: Metal
- Controls: Four Buttons
- Case Size: 135x144x36mm
- Weight: 632g
- PC Communications: USB Port for PC Control & Firmware Upgrade
- External Port: 2-6S Balance Socket-XH, Temperature Probe Socket, Battery Socket, DC Input, Micro USB Port for PC.
- Delta Peak Detection for NiMH/NiCd: 5-15mV/cell / Default: 4mV/cell
- Charge Cutoff Temperature: 20°C/68°F-80°C/176°F(adjustable)
- Charge Voltage: NiMH/NiCd: Delta peak detection
  - LiPo: 4.18-4.25V/cell
  - Lilon: 4.08-4.2V/cell
  - LiFe: 3.58-3.7V/cell
- Balance Current: 200mA/cell
- Reading Voltage Range: 0.1-25.8V/cell
- Battery Types/Cells: LiPo/Lilon/LiFe: 1-6cells
  - NiMH/NiCd: 1-15cells
  - Pb: 2-20V
- Battery Capacity Range: NiMH/NiCd: 100-50000mAh
  - LiPo/Lilon/LiFe: 100-50000mAh
  - Pb: 100-50000mAh
- Charge Current: 0.1A-6.0A
- Safety Timer: 1-720minutes off
- Charge Wattage: 50W
- Discharge Current: 0.1A-2.0A
- Discharge Cut-off Voltage: NiMH/NiCd: 0.1-1.1V/cell
  - LiPo: 3.0-3.3V/cell
  - Lilon: 2.9—3.2V/cell
  - LiFe: 2.6-2.9V/cell
  - Pb: 1.8V
- Discharge Wattage: 5W
- Balance Cells: 2-6 cells
- Memory: 10 different charge/discharge profiles
- Charge Method: CC/CV for lithium types and lead (Pb) batteries
  - Delta-peak Sensitivity for NiMH/NiCd.

## B.7 Voltage Regulator – DROK LM2596

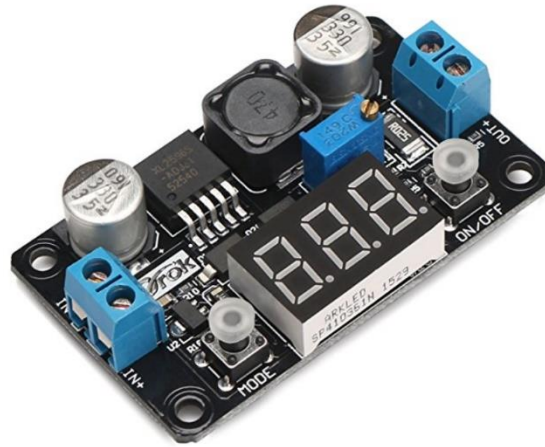

Parameters:

Input Voltage: DC 4~40V(the input voltage should be higher than output voltage at least 1V)

Output Voltage: DC 1.25~37V(continuously adjustable)

Output Current: 2A(for stable operation), 3A max.

Voltmeter: 0~40V

Voltmeter Accuracy: .+/-0.1V

Internal Oscillation Frequency: 150KHz

There is a large area of copper on its back to enhance heat dissipation

## B.8 Circuit Breaker (fuse) – Digiten Auto Standard Blade Type ATV Fuse



Suitable for ATC/ATO blade fuse, up to 13A.

In-line screw type

Wire spec:16 AWG,cable total length is 12 inches.

## B.9 Weatherproof Enclosure – L-Com Weatherproof Windowed Enclosure



www.L-com.com

### Product Description

The box is a rugged weatherproof enclosure that is ideal for both indoor and outdoor applications. Constructed from molded Fiberglass Reinforced Polyester (FRP), it is well suited for high temperature or corrosive environments. The mounting flange allows it to be wall mounted as well as on a flat surface. The raised lid features a stainless steel continuous hinge and stainless steel quick release latches with padlock hasps. The raised lid is fully gasketed. The enclosure material is UV stabilized and comes in neutral beige color.

The NBW121005 is ideal for use as electrical junction boxes or instrumentation enclosures in highly corrosive environments including oil refineries, chemical processing plants, waste water treatment facilities, marine installations, electroplating plants, agriculture environments, food processing plants, and agricultural environments. This enclosure is also suitable as instrument housing in both indoor and outdoor applications as the window provides easy visual inspection of interior components.

### Specifications

Enclosure Material	Fiberglass Reinforced Polyester
Enclosure Color	Gray (RAL 7036)
Weight	6.3 lbs (2.8 kg)
Outside Dimensions (max)	13.3 x 11.3 x 5.5 inches (33.7 x 28.7 x 13.9 cm)
Inside Dimensions	12.0 x 10.0 x 4.8 inches (30.4 x 25.4 x 12.1 cm)
Flame Rating	UL 94-5V
RoHS Compliant	Yes
Ratings*	NEMA Type 4, 4X / IP66

\*Note: Enclosure ports (Cable conduit connector and N-type holes for lightning protectors or connectors) must be properly sealed to maintain NEMA Type 4, 4X / IP66 rating.



**Enclosure Dimensions**

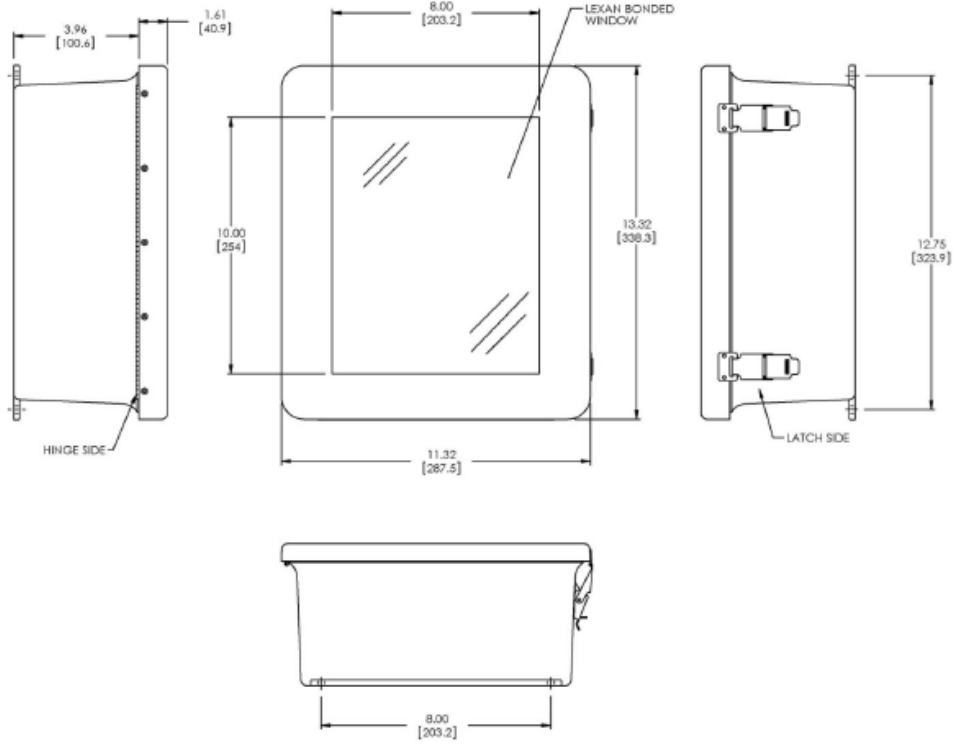

L-com, Inc. 50 High St., West Mill, 3<sup>rd</sup> Floor, Suite #30 North Andover, MA 01845  
 www.L-com.com E-mail: sales@L-com.com Phone: 1-800-343-1455 Fax: 1-978-689-9484  
 © L-com, Inc. All Rights Reserved. L-com Global Connectivity and the L-com logo are registered marks.

## 12x10x5 Inch Weatherproof Enclosure with Transparent Lexan Window Model: NBW121005

### Applications and Features

#### Features:

- Molded Fiberglass Reinforced Polyester (FRP) industrial Enclosure
- Bonded Lexan window
- Stainless steel quick release latches with padlock hasps
- Fully gasketed raised lid & integral mounting flange
- NEMA Type 4, 4X / IP66 rated

#### Application:



- Remote Wireless LAN WiFi equipment installations
- Indoor and outdoor installations
- Rapid Deployment Installations
- Corrosive environments & hotspot applications
- Protection of equipment from theft or damage



## B.10 Silica Packets – Dry & Dry 5-gram Silica Packets

### 9. Physical and Chemical Properties

**Appearance:** White granular powder.  
**Odor:** Odorless.  
**Solubility:** Negligible (< 0.1%)  
**Specific Gravity:** 2.10  
**pH:** 3 - 8 (in 5% slurry) %  
**Volatiles by volume @ 21C (70F):** 0  
**Boiling Point:** 2230C (4046F)  
**Melting Point:** 1610C (2930F)  
**Vapor Density (Air=1):** Not applicable.  
**Vapor Pressure (mm Hg):** Not applicable.  
**Evaporation Rate (BuAc=1):** No information found.

## Appendix C Bibliography

- Adafruit. (2018). 16mm Illuminated Pushbutton - Blue Momentary. New York City, New York, USA.
- Agarwal, T. (n.d.). *ElProCus*. Retrieved from Electronics Projects Focus:  
<https://www.elprocus.com/programmable-logic-controllers-and-types-of-plcs/>
- Allied Electronics & Automation. (2018). Raspberry Pi RASPBERRY PI 2, MODEL B. Fort Worth, Texas, USA.
- Benchoff, B. (2016, January 5). *WIFI ALLIANCE INTRODUCES 802.11AH*. Retrieved from Hackaday:  
<https://hackaday.com/2016/01/05/wifi-alliance-introduces-802-11ah/>
- Droking. (2018). Retrieved from DROK: LM2596 DC Volt Regulator:  
[http://www.droking.com/index.php?route=product/product&product\\_id=1863](http://www.droking.com/index.php?route=product/product&product_id=1863)
- Dry & Dry. (2015, December 8). 5 gram X 30 PK "Dry & Dry" Silica Gel Desiccant -FDA Compliant Food Safe. California, Brea, USA.
- Encoder Couplings* . (2018). Retrieved from Encoder Products Company: <http://encoder.com/couplings-shaft-magnetic/>
- Florida Climate Center*. (2018). Retrieved from The Florida State University:  
<https://climatecenter.fsu.edu/products-services/data/other-normals/relative-humidity>
- Global Programmable Logic Controllers Category - Procurement Market Intelligence Report*. (2017, October). Retrieved from Spend Edge: <https://www.spendedge.com>
- Infinite Electronics International, Inc. (2011). 12x10x5 Inch Weatherproof Windowed NEMA Enclosure Only. North Andover, Massachusetts, USA.
- Intellicast*. (2018). Retrieved from Intellicast:  
<http://www.intellicast.com/Local/History.aspx?location=USFL0372>
- International Telecommunications Union . (2015). *ITU-T G.9959*. Geneva: International Telecommunications Union .

*MaxAmps*. (n.d.). Retrieved from maxamps.com  
Merriam-Webster. (2018). *Merriam-Webster Dictionary*. Retrieved from Merriam-Webster Dictionary Online: <https://www.merriam-webster.com/dictionary/rack>  
Petruzella, F. D. (2005). *Programmable Logic Controllers, 3rd Edition*. New York: The McGraw-Hill Companies, Inc.  
Powerwerx. (2018). Powerwerx Watt Meter, DC Inline Power Analyzer, 45A Continuous, 12 Gauge, Bare Wire Ends. Yorba Linda, California, USA.  
SkyRC Technology Co., L. (2018, November). Retrieved from Skycrc: [https://www.skyrc.com/iMAX\\_B6AC\\_V2\\_Charger](https://www.skyrc.com/iMAX_B6AC_V2_Charger)  
*Time and Date*. (2018). Retrieved from Sunrise, Sunset, Day Length: <https://www.timeanddate.com/sun/usa/orlando?month=6>  
*US Digital Products*. (2018). Retrieved from US Digital: <https://www.usdigital.com/products/ma3#description>  
Z-Wave.Me. (2017). Z-Wave.Me RaZberry - Z-Wave Plus GPIO Card for the Raspberry Pi. Switzerland.